

The journey has only just begun

Nordic Transport Group
2018 annual report

Approved at the Group's annual general meeting on 4 April 2019
CVR No. 36471573
Chairman: Johan Lønberg

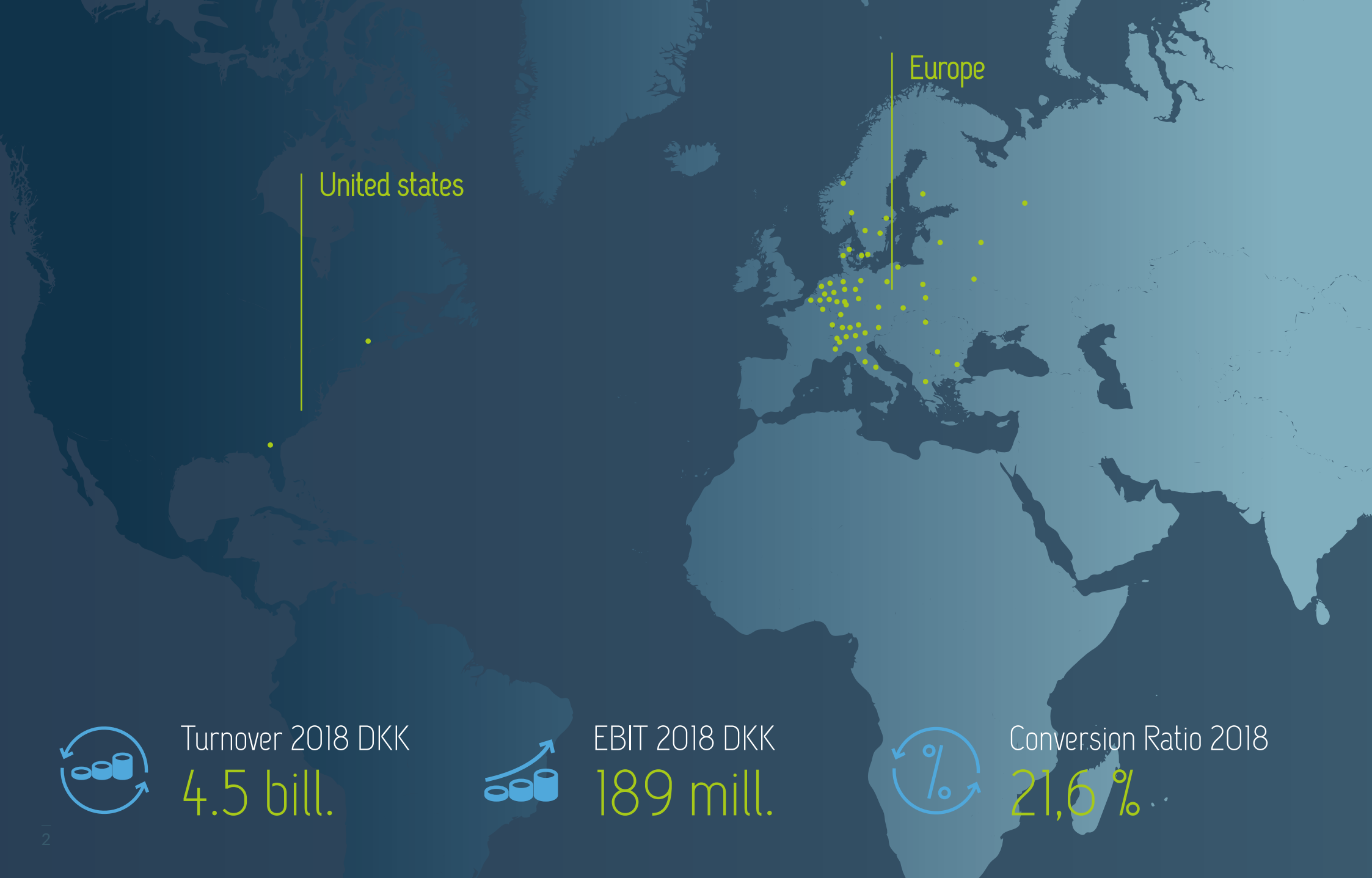



United states

Europe



Turnover 2018 DKK
4.5 bill.



EBIT 2018 DKK
189 mill.



Conversion Ratio 2018
21,6 %

Nordic Transport Group

Always moving forward

Introduction

Nordic Transport Group (NTG) is one of the fastest-growing freight forwarders in Europe. We move goods throughout the world, but never mind the trucks, ships and aircrafts – at the end of the day it's all about people.

NTG is not like any other freight forwarding company, as we are partly owned by our employees, who are the most dedicated in the industry. This is clearly reflected in the consideration and care we put into everything we do.

Furthermore, NTG comprises more than 80 companies and through carefully selected acquisitions and partnerships, we are continuously expanding and enhancing our services and market position.

The journey has only just begun.



Employees
↑ 1.300



Offices
↑ 100



NTG trailers
↑ 2.500

2018 Financial Highlights

Income (DKK '000)	2018	2017	2016*	2015*	2014*
Net revenue	4.512.137	2.896.181	2.134.499	1.711.856	909.387
Gross profit	876.608	545.964	402.497	319.446	141.238
Operating profit before amortisations, depreciations and special items (adj. EBITDA)	196.822	160.255	106.268	60.917	30.409
Operating profit before special items (adj. EBIT)	189.156	157.589	101.327	56.649	29.967
Special items, net	-17.563	-1.161	0	0	0
Net financial items	-14.772	-7.735	-2.739	3.494	255
Profit for the year	111.523	111.460	73.834	44.011	24.466

Cash flow (DKK '000)

Operating activities	117.360	82.779	105.078	68.687	95.541
Investing activities	-19.613	-36.539	-11.857	-8.486	-55.964
Free cash flow	97.747	46.240	93.221	60.201	39.577
Financing activities	-108.853	-47.721	-26.901	1.898	8.858
Cash flow for the year	-11.106	-1.481	66.319	62.099	48.674

* figures are presented according to Danish GAAP (Årsregnskabsloven). Refer to note 1.2 regarding conversion to IFRS

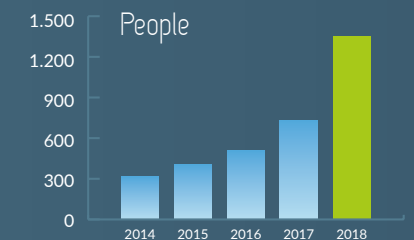
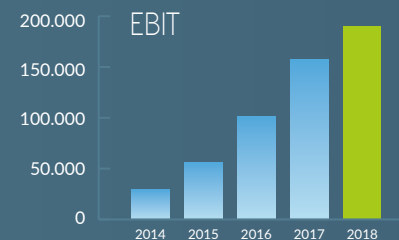
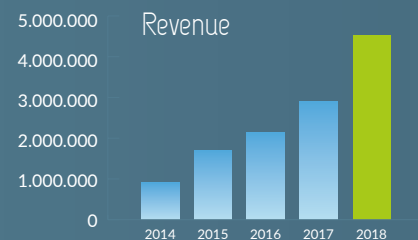

Financial position (DKK '000)	2018	2017	2016*	2015*	2014*
Investment in property, plant and equipment	17.753	17.720	1.229	1.082	0
Balance sheet total	1.373.312	771.381	558.176	447.700	255.828
Net working capital	-97.799	-35.104	-91.711	-110.396	-82.034
Net interest-bearing debt	-89.475	-96.460	-111.217	-100.017	-39.816
NTG A/S' shareholders' share of equity	114.009	91.869	38.854	20.405	557
Non-controlling interests	93.898	65.696	36.747	29.101	12.856

Financial ratios

Gross margin	19,4%	18,9%	18,9%	18,7%	15,5%
Operating margin	4,2%	5,4%	4,7%	3,3%	3,3%
Conversion ratio	21,6%	28,9%	25,2%	17,7%	21,2%
Return on equity	61,0%	95,6%	136,0%	211,5%	164,6%
Solvency ratio	15,1%	20,4%	13,5%	4,6%	8,3%

Employees

Average number of employees	1.349	734	509	409	320
-----------------------------	-------	-----	-----	-----	-----

* figures are presented according to Danish GAAP (Årsregnskabsloven). Refer to note 1.2 regarding conversion to IFRS

19,4 %
Gross margin

21,6 %
Conversion ratio

61,0 %
Return on equity

Table of content

Management report

Fact sheet – NTG in numbers	2-3
Group Management commentary	8-9
NTG's history 2011-2018	10-11
The secret to our success: It's all about people	12-13

Strategy and financial results

Strategic initiatives to ensure growth	16
Expectations for 2019	17
Our greatest accomplishments in 2018	18-19
Business segment review, Road & Logistics	20-21
Business segment review, Air & Ocean	22-23

Governance, risk and responsibility

How NTG is structured	26-27
Presentation of Board of Directors	28-29
Presentation of Executive Board	30-31
Risk Management	32-33
Corporate social responsibility	34-36

Financial statements

Group financial statements and disclosures

Consolidated financial statements	37-42
Notes on the financial statements	43-70
Group structure	71
Financial highlights	72

Statements

Management's statement	73
Independent auditor's report	74-75

Parent company financial statements 76

A stylized, monochromatic map in shades of blue and white. The map shows a grid of streets and several irregular shapes representing parks or green spaces. One large green space in the lower-left quadrant is highlighted with a slightly lighter shade. The text 'Mulhouse', 'Kassel', and 'Poznan' is overlaid on the map. 'Mulhouse' is in a light blue font, 'Kassel' is in a dark blue font, and 'Poznan' is in a white font. The word 'Area' is also faintly visible in the background.

Mulhouse
Kassel
Poznan

Group Management commentary

2018 has been an exciting and busy year for Nordic Transport Group. A revenue growth of 56 % to DKK 4.512 million, with the addition of more than 590 new people speaks for itself. Of the growth in topline, 43 % came from acquisitions, while 13 % was organic growth.

Major acquisitions

One main event was the transformational acquisition of the Swiss full-service transportation and logistics provider, Gondrand Group in early 2018. With annual revenues of approximately DKK 1.200 million, Gondrand increased our topline by almost 30 % in 2018, adding significant scale to our business. Gondrand was a perfect strategic match for NTG in terms of activities and geographical footprint, paving the way to new key markets.

Taking over a sizable group like Gondrand is a big undertaking. Integration has progressed well, but will continue in 2019. We knew that Gondrand was facing challenges and needed organisational changes, and actions were taken which had a negative

impact on our earnings in 2018, but improved the long-term prospects of the investment.

In March 2018, NTG acquired 51 % of Danish NS Transcargo (renamed as NTG Nielsen & Sørensen) strengthening NTG's position in the walking-floor and silo transport business.

In September 2018, NTG acquired 61% of Danish Combino East (renamed to NTG Frigo East, specialising in the transportation of frozen and cooled goods in Eastern Europe. Both companies have been successfully integrated and have already this year harvested most of the expected synergies.

Active in 31 countries

In addition to acquisitions, NTG has entered the US market by opening an office in Atlanta, offering Air & Ocean services. The plan is to open a few more offices in the US during 2019. Entering the US market is a step on the way to becoming a global transport and logistics provider. Today NTG is active in 31 countries.

We are not only growing in terms of revenue numbers and geographies. We are also serving bigger customers, requiring end-to-end transport solutions. This fits well into our ambition to be the preferred transport partner.

Price, flexibility and a high level of service

NTG is a people's business, and our strong growth would not be possible without the dedicated and hard-working 1.335 employees in our 110 offices. We are also convinced that our unique partnership-based business model with a focus on shared ownership with local management teams is key to our success. Shared ownership provides the incentive to go the extra mile; this is to the benefit of our customers as well as the company. We are not only competitive when it comes to price – flexibility and a high level of service are also key to our success.

Looking forward to 2019

We expect 2019 to be equally exciting and busy. We certainly expect to continue the growth journey, organically as well as through acquisitions. One of our most important goals is the planned listing of NTG on Nasdaq Copenhagen.

The Board of Directors was strengthened for the future by the appointment of two new independent board members, Finn Skovbo Pedersen and Ulrik Ross. Finn Skovbo Pedersen brings with him vast industry knowledge, while Ulrik Ross is an experienced investment banking executive. Former CEO and founder of NTG A/S, Jørgen Hansen, stepped into a position as Vice Chairman of the Board of Directors in mid-2018.

As part of the preparations for NTG's IPO, two new co-CEOs were appointed during 2018: Jesper Petersen took on the role of CEO Road & Logistics and Mikkel Fruergaard took on the role of CEO Air & Ocean. Both Jesper and Mikkel have been part of the prior executive management team and will continue the growth strategy which NTG has had from the start. To further develop the Group's internal processes and compliance, Christian D. Jakobsen was appointed as CFO at the beginning of 2018. Christian has previously held senior financial positions within the transport industry, including experience working for public companies.

“

We expect 2019 to be equally exciting and busy.

Employees
+590

Companies
+17

Organic Growth
+13%

Our story since it all began in 2011

Our freight adventure had its beginning in April 2011, when Nordic Transport Group was founded by Jørgen Hansen, who had worked in the transport sector for decades.

Jørgen's goal was to create one of Europe's leading transport companies via partnerships with the most highly skilled small and medium-sized players in the business, and he soon succeeded.

Today Nordic Transport Group has more than 80 companies all over the world – and more are joining.

“
Jørgen Hansen's goal was to create one of Europe's leading transport companies – and he soon succeeded.”

2011 Nordic Transport Group is founded by Jørgen Hansen

- Nordic Transport Group A/S and NTG Nordic A/S established
- EAT Solution A/S acquired and renamed NTG Continent A/S
- NTG Frigo A/S established (DK)
- A branch of NTG Nordic A/S established in Aarhus (DK)

2012 New start-ups in Latvia and Sweden

- ATS Cargo uab acquired and renamed NTG Lithuania uab
- NTG Frigo Slovakia s.r.o. established
- NTG Latvia Sia established
- NTG Växjö AB established in Sweden
- NTG Continent A/S establishes a branch in Køge (DK)

2014 More start-ups are established in Germany, Sweden and Denmark

- NTG East A/S established
- New Europe Transport AB acquired in Sweden and renamed NTG East AB
- NTG Hamburg GmbH established in Germany
- HC Schmidt and Dahmen Logistics GmbH acquired in Germany and renamed NTG Logistics GmbH
- NTG Continent AB established in Sweden
- NTG Terminals I A/S established (DK)
- NTG Terminals II A/S established (DK)
- Acquisition of Itella Logistics' Danish air and ocean freight activities

2015 Entered the Finnish market

- NTG East A/S establish a branch in Hvidovre (DK)
- NTG East AB establish a branch in Istanbul (TR)
- NTG Poland S.p.z.o.o. established as a start-up
- Acquisition of Itella Logistics in Denmark, Finland, Norway and Sweden
- NTG Trophy A/S established
- Acquisition of Peak Logistics AB (SE+BE)

2016 New offices in Germany and Norway

- NTG Agencies OY established (FI)
- NTG Logistics AB – Borås established (SE)
- New NTG Global branch office in Kristiansund (NO) and Tallin (EE)
- NTG Hungary established
- New NTG Solution office in Kielse (PL)
- New NTG Continent AB office in Lübeck (DE)
- NTG Domestic AB – Jönköping established (SE)

2017 Growing Eastern European presence

- Polar Logistics in Finland, Russia, Poland, Germany, Kazakhstan, Ukraine, Czech, the Netherlands and Belarus join NTG
- NTG Ocean established in DK, NL and the USA
- NTG Courier A/S (DK) established
- Cargo 2000 A/S (DK) acquired
- NTG Domestic A/S (DK) established

2018 Expanding our geographical footprint in Europe and China

- Swiss Gondrand Logistics Group acquired. 60 branches in CH, DE, NL, HU, CZ, IT, Hong Kong and China
- NS Transcargo A/S (DK) acquired and renamed NTG Nielsen & Sørensen A/S
- NTG Road GmbH (DE) established
- Combino East A/S (DK) acquired and renamed NTG Frigo East A/S
- NTG Air & Ocean (Atlanta, USA) established
- FTS UK GmbH acquired and merged with NTG Frigo GmbH

The secret to our success: It's all about people

Freight forwarding is a people's business. Through our unique partnership model we believe we can attract the best and most entrepreneurial people in the market.

The partnership model is the backbone of NTG and enables us to attract the most dedicated leaders in the industry by giving them an active ownership stake. NTG's partnering model is based on Nordic Transport Group A/S owning at least 51 % of the subsidiaries and local partners holding the remaining shares.

Empowerment of employees

NTG is committed to fostering a culture where employees are treated with respect and fairness and are part of an engaging work environment. The model is based on entrepreneurship and trust, enabling the empowerment of employees, and has a proven track record with many start-ups returning positive results within the first year of operation. This is why we say: 'There are people behind EVERY shipment'.

Asset-light company

NTG runs an asset-light business model with strong cash conversion. The surplus cash has been used to grow the company and the CAGR turnover has been 67 % since 2011.

It is the clear goal of the Group's back-office functions to support operations in the most efficient way possible, both in terms of costs and processes. We reach this goal by creating lean administration processes, cutting through 'red tape' and maintaining a state-of-the-art digital platform.

Solid digital platform

NTG has a strong focus on digitising, automatising and standardizing central business and finance functions, thereby freeing up employees' time. Instead, our employees can use their time creating value for the Group's customers. In addition to this, a solid digital platform secures benefits via economies of scale.



This is why we say:
'There are people behind
EVERY shipment'.

Strategy and financial results

47°0'12"N

Strategic initiatives to ensure growth

NTG has a clear growth strategy, where a combination of acquisitions, greenfield start-ups and organic growth will secure our future progress. This is well-known territory to NTG and has been the strategy since our inception in 2011.

The growth of the freight forwarding business exceeds the growth in GDP; the multiplier is believed to be 1,5-3 depending on market and trade lanes. The freight forwarding market is still very fragmented and the top 20 companies* are estimated to control 30 % of the total freight forwarding market. This leaves room for a growth-oriented Group like NTG to move into the remaining 70 % of the market by focusing on acquisitions which the big players find too small.

Three strong acquisitions

NTG acquired 100 % of the Swiss-based transport group Gondrand International on 1 April 2018. In recent years, Gondrand International had been struggling with negative results and internal challenges. The IT platform was obsolete and transparency and entrepreneurship were very low. NTG has changed the management in many of Gondrand International's

business units, and has realised synergies through redundancies. The effect has been a little slower than anticipated but the results have improved. The goal is to integrate Gondrand International into NTG's partnering model and platforms.

The acquisition of Gondrand International has opened new markets for NTG, with strong positions in Germany, Switzerland, the Netherlands, and other central European countries. In NTG's financial statements for 2018, the acquisition of Gondrand International contributed approx. DKK 900 million in revenue.

NTG acquired a 51 % ownership interest in NS Transcargo A/S (now NTG Nielsen & Sørensen A/S) on 1 March 2018, and a 61 % ownership interest in Combino East (now NTG Frigo East Aps) on 1 September 2018. Both companies are Danish-based, well-run and have track records of good financial results, which from day one have contributed positively to the Group's operational results. NTG's goal is to integrate the two companies with the Group's existing business and provide a platform for future growth. In 2018, the two acquisitions contributed with approx. DKK 156 million in revenue.

Five new start-ups

Entrepreneurship is constantly on the agenda, and NTG continues to fund and support new, promising start-ups within

the industry. During the start-up phase NTG actively aids local partners on the path towards growth and profitability, gradually trimming down support as the company matures.

Start-ups give the Group opportunities to be flexible, adding new product offerings and new geographies, and allowing us to work with the best people in each business area.

In 2018, NTG partnered in five new start-ups, representing both of the Group's business segments. The start-ups cover both new market segments and new locations.



This leaves room for a growth-oriented group like NTG to move into the 70 % of the remaining market, focusing on acquisitions, which the big players find too small.

* Industry estimates based on Journal of Commerce

Expectations for 2019

The economic indicators and data suggest that the capacity pressure in the industry will continue in 2019.

This outlook assumes stable developments in the markets in which NTG operates. OECD and IMF project global economic growth at the level of 3,5-3,7 % in 2019, with lower growth rates in Europe and the USA and higher growth in Asia.

Continued focus on acquisitions

In 2019 NTG expects to realise a revenue between DKK 5.000 and 5.500 million, with an expected EBIT before special items

in the range of DKK 200-230 million. This outlook is based on a stable economic environment in the primary markets in which the Group operates, mainly Northern- and Central European Road transport and International Air & Ocean transport. NTG also expects the results to be influenced by full-year volume effects and synergies from acquisitions carried out in 2018.

NTG will still be focusing on acquisitions, both to expand our footprint and to integrate them into our current business. We expect that the continued integration effort of Gondrand International will result in a positive adj. EBIT contribution from the acquisition in 2018.

The new year starts well

At the beginning of 2019, NTG made two further acquisitions: the UK-based transport company DAP (UK) Ltd. and the Japan-based TAK International Ltd. Both acquisitions will open up new markets for the Group and are expected to contribute with approx. DKK 100 million in revenue and DKK 5-10 million in adj. EBIT.

Besides acquisitions, NTG has partnered with new start-ups in Vietnam, Croatia and Romania, effective in Q1 2019. These investments are expected to generate a negative adj. EBIT of up to DKK 10 million in 2019.



“
NTG will still be focusing on acquisitions,
both to expand our footprint and to
integrate them into our current business.”

Our greatest accomplishments in 2018

2018 has been a successful year overall, with high organic growth, strategic acquisitions, and start-ups expanding our geographical footprint significantly.

Results for the year are in line with expectations set out last year, as the Group realised an increase in both revenue and adj. EBIT. In the following we will list our greatest accomplishments in our two business segments and concerning Finance, IT & Administration.

NTG Road & Logistics

Our success with existing platforms in NTG Road & Logistics has continued. The organic growth on turnover was 16 % and 8 % on adj. EBIT.

The integration of Polar Group, acquired in 2017, has been successfully completed and the synergies realised above expectations. The acquisition of Gondrand International meant a large increase in Road & Logistics' activities in Germany, Switzerland

and the Netherlands, along with additions of new locations across Central Europe, strengthening our existing network.

NTG Air & Ocean

The business segment successfully navigated through the competitive market, focusing on integrating start-ups from 2017 and the integration of Gondrand International's activity. The latter provided entry into the East Asian market, with several locations in China and Hong Kong.

Air & Ocean experienced a growth of 112 % on turnover, in large part driven by acquisitions, and a growth of 25,2 % on adj. EBIT.

In 2018 it was decided to convert Air & Ocean's Transport Management System (TMS) into a modern cloud-based solution. The new TMS will provide a high degree of transparency and better efficiency compared to existing systems. Implementation of the new system commenced in 2018 and is expected to be finalised in 2019.

Finance, IT & Administration

In autumn 2018 NTG implemented a new reporting and consolidation system, which supports the Group's strategy of digitisation and lean administration. The implementation has significantly improved the internal financial reporting process. During 2018, the Group completed conversion of accounting practice to IFRS, to comply with stock market requirements. Both initiatives are cornerstones in the Group's IPO preparations.

In 2018 Gondrand International's headquarters was closed down and the migration from Gondrand International's IT platform was commenced with expected finalisation in Q2 2019.

In the summer of 2018, NTG concluded the first stage of an ISO certification program to document the Group's compliance with quality and environmental management systems. This resulted in many of the Group's subsidiaries and the parent company Nordic Transport Group A/S obtaining ISO 9001:2015 (quality) and ISO 14001:2015 (environment) certificates. The effort will continue in 2019.

56 %
Total growth

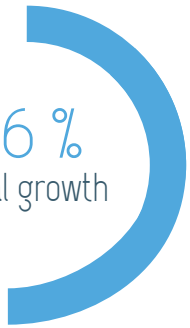

47 %
Growth,
Road & Logistics



112 %
Growth,
Air & Ocean

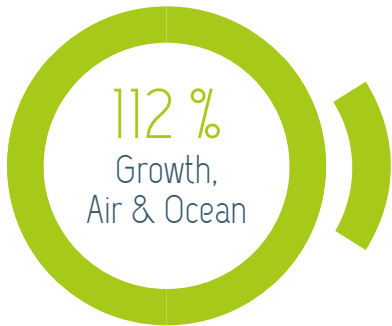

“
2018 has been a
successful year overall.”

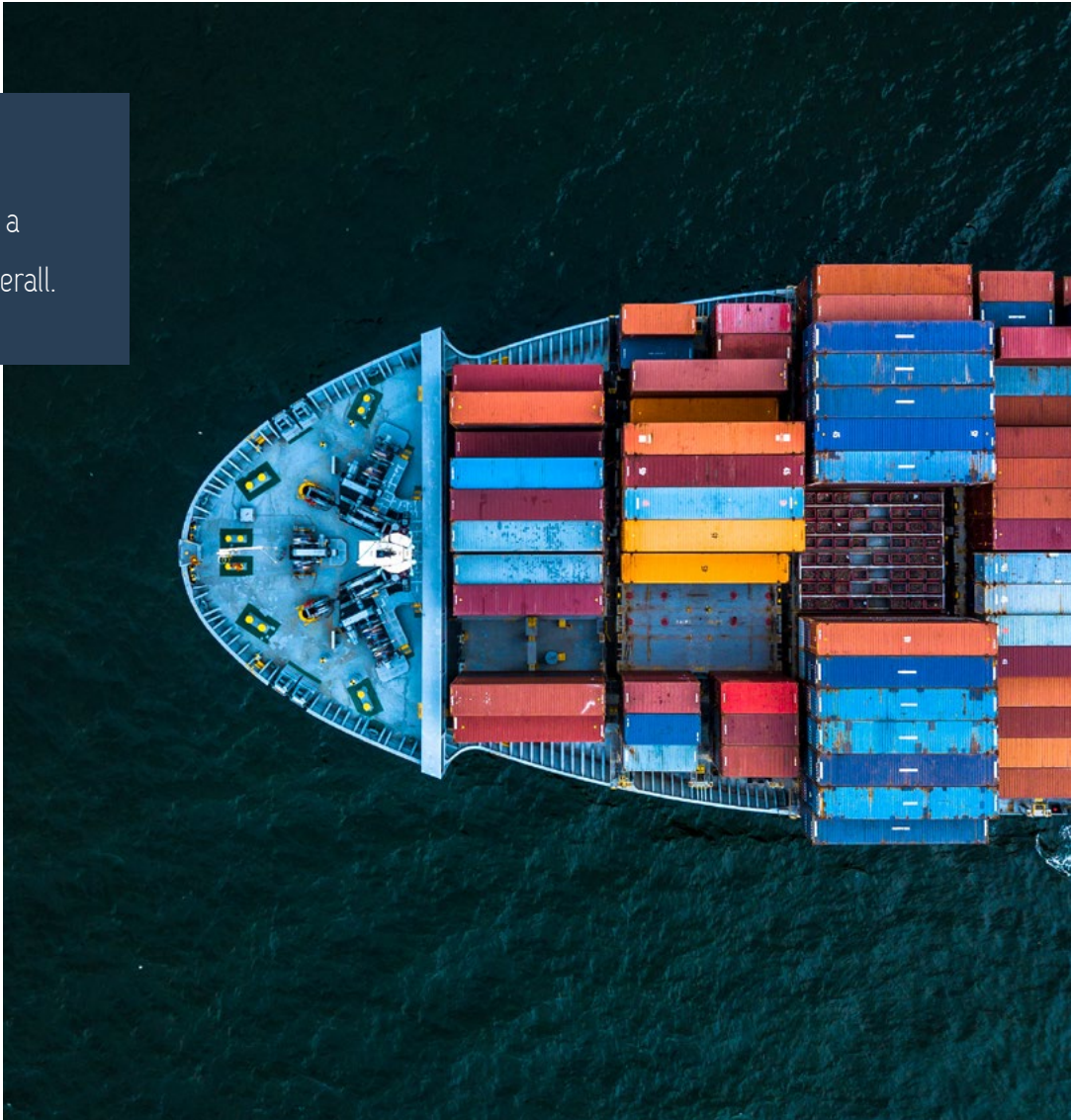

On time



km/h

Helsinki
Copenhagen
Frankfurt
Warsaw

20

Business segment review, Road & Logistics

Last year saw a rising activity level in the segment, where margins were affected by increasing pressure on capacities. In 2018, a total of five new countries were added to the segment's geographical presence.

Financial review

Acquisitions had a large impact on the segment throughout the year, due to the added activity of Gondrand, NS Transcargogo and Combino East. Net revenue for the year totaled DKK 3.641 million, up from DKK 2.485 million in 2017, representing a 47 % increase. The segment's gross margin remained stable at 18 % in both 2018 and 2017.

The segment's adj. EBIT totalled DKK 171 million in 2018, an increase of 18 % from DKK 145 million in 2017, and EBIT margin before special items was 4,7 % in 2018 versus 5,8 % in 2017. Adj. EBIT margin was affected negatively by the acquisition of Gondrand, where the Road business has historically shown decent volumes, but low operating margins.

Excluding Gondrand, the segment's adj. EBIT totalled DKK 173 million in 2018.

Accomplishments in 2018

Within the Road division the focus was on finalizing the successful integration of the Polar Group, which was acquired in 2017, and the acquisitions of Gondrand, NS Transcargogo and Combino East. NS Transcargogo and Combino East were both well-run companies with strong management, and both companies were successfully integrated within a couple of months, benefitting from the economies of scale and the network within NTG.

Goals for 2019

In 2019, the segment's market share will be raised by leveraging NTG's unique partnering model to stimulate organic growth, and by completing further acquisitions which complement the segment's strategies.

The integration of Gondrand into the Group's partnering model is expected to be finalised during 2019, increasing the segment's margins to target levels by providing much-needed entrepreneurship and motivation.

EBIT DKK
171 mill.

Business segment review, Air & Ocean

Acquisitions and new start-ups have grown the segment to more than double its size during 2018 alone, and margins have improved. Volumes are still on the rise, creating the foundation for future growth in the years to come. The segment is now present in 22 countries, spanning from China to the USA.

Financial review

Gondrand had a large impact on the Air & Ocean business, opening new locations in China, Hong Kong, Switzerland, Italy, Germany and the Netherlands. Net revenue for the year amounted to DKK 871 million, with an increase of 112 % from DKK 410 million in 2017. The segment's gross margins improved to 25,9 % in 2018, compared to 24,1 % in 2017.

The segment's adj. EBIT totalled DKK 15 million in 2018, increasing from DKK 12 million in 2017, and adj. EBIT margin was 1,7 % in 2018 versus 2,9 % in 2017. Adj. EBIT was affected negatively by the acquisition of Gondrand.

Accomplishments in 2018

In Air & Ocean, the main focus has been on onboarding companies from the acquisition of Gondrand and opening new markets through start-ups. At the end of 2018, the segment's efforts in the US were re-booted with the opening of a new

office in Atlanta, Georgia, where the Group will centralise its US leadership.

In 2018, the Air & Ocean business started its transition to a new transport management system, which is expected to drive further efficiencies across the network.

Goals for 2019

One of the main goals for 2019 is to strengthen the segment's position in the US market by bringing onboard partners to open new offices. In addition to US efforts, the segment has already in the beginning of 2019 alone opened locations in four new countries – two in Europe and two in Asia.

Efforts to integrate Gondrand into NTG's existing network will be concluded in 2019, realising the full potential of the acquisition.

REVENUE DKK
+4.61 mill.

ATL CPH
BOS FRA



Governance, risk and responsibility

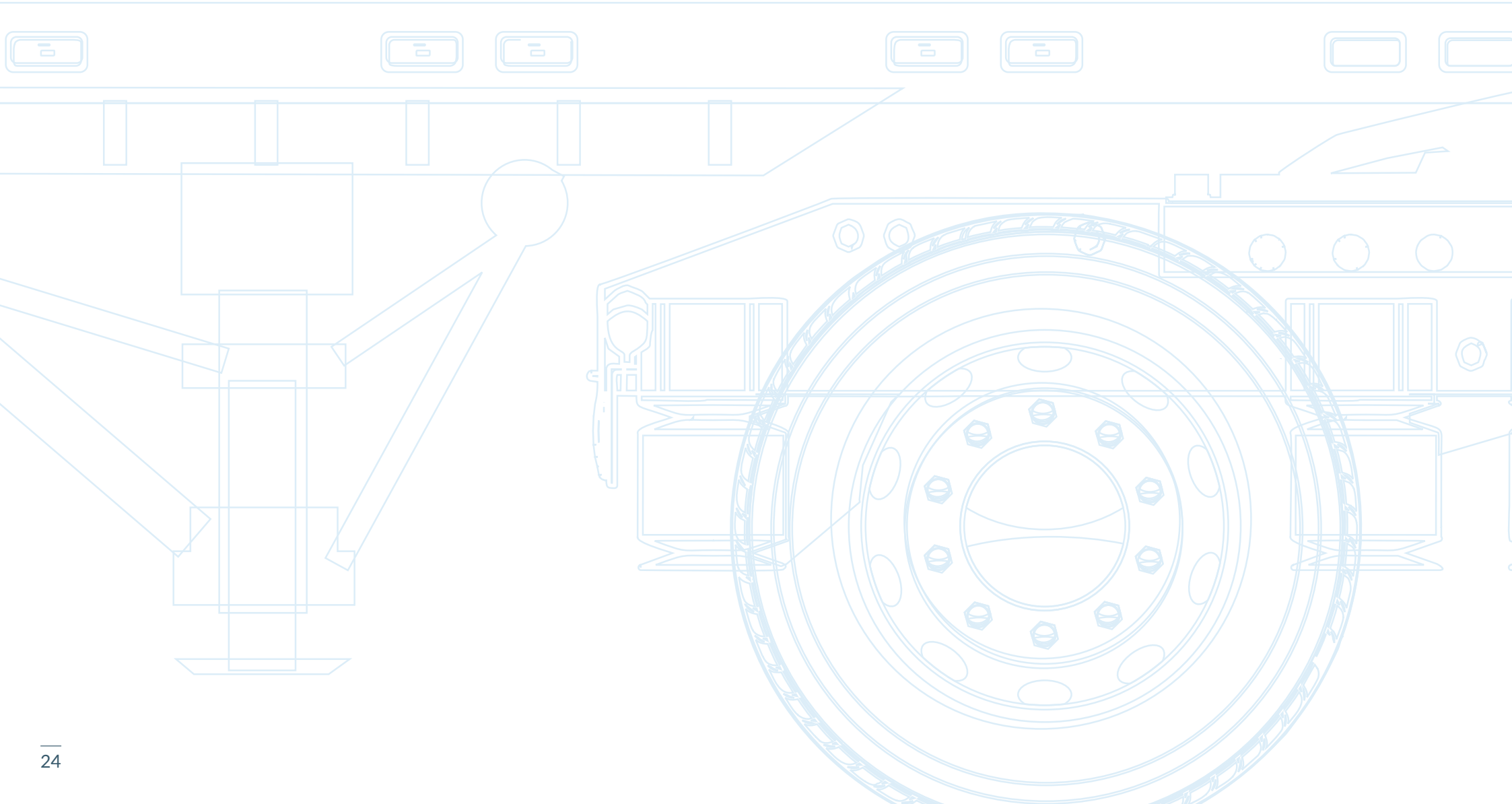

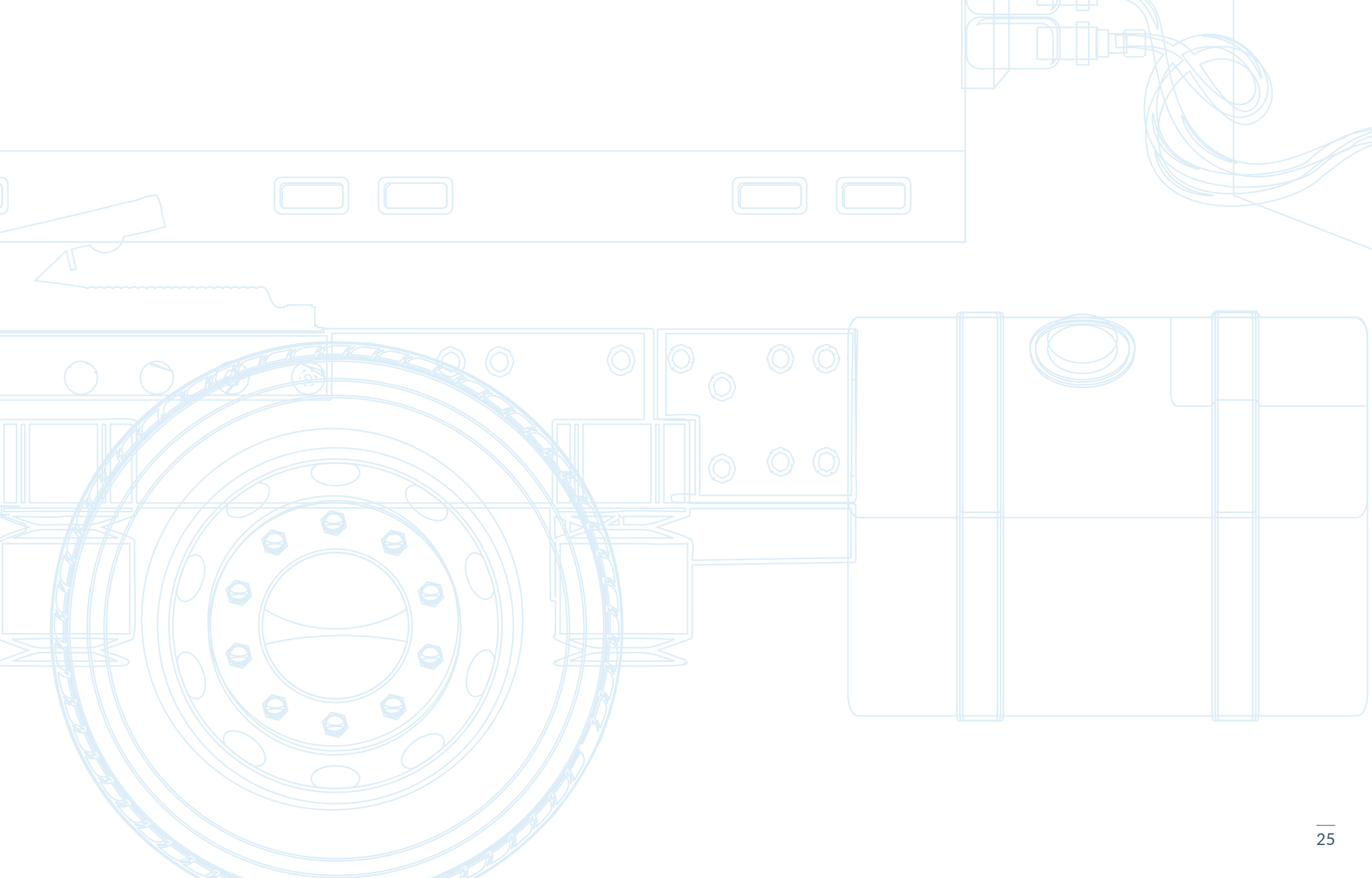

How NTG is structured

NTG's governance model is designed with the overall goal of securing the right leadership for driving long-term value creation for the Group's stakeholders.

The Board of Directors and the Executive Board are jointly responsible for leading the Group's activities, and the division of responsibilities between the two boards is stipulated in NTG's Rules of Procedure. Generally, the Board of Directors is responsible for setting the Group's strategy and is involved in large-scale decisions with a pervasive impact on the Group. The Executive Board's main responsibility is to carry out the Group's strategy and oversee daily activities in the company's operations. Final authority rests with the Group's shareholders at the General Assembly.

Board of Directors

In the middle of 2018, the Board of Directors was restructured as part of the preparation for the Group's planned IPO in 2019. This brought a further strengthening of the Board by adding three members with a large experience base within the company's industry, as well as within international finance. The Board of Directors now consists of seven members, two of whom are considered independent according to the Danish Recommendations on Corporate Governance.

During 2018, the Board of Directors held seven ordinary board meetings. The agenda of these meetings was to a large extent dictated by the annual cycle of the Board's work, and preparations for the Group's planned IPO.

Executive Board

2018 saw a reorganisation of the Executive Board, where the Group's executive management was developed to ensure the correct competencies for operating a publicly listed company. The reorganisation led to the appointment of two CEOs, one within each of the company's main operating segments, and the employment of a new CFO to secure compliance with the stock exchange's requirements.

The Executive Board exercise direct leadership of the individual group subsidiaries' Managing Partners and Heads of group functions, thereby raising organisational agility and speeding up decision processes.



Our governance structure is designed with the overall goal of securing the right leadership for driving long-term value creation.

General Assembly

Board of Directors

Executive Board

CEO, Road & Logistics

CEO, Air & Ocean

CFO, Finance & IT

Group
Directors

Group
Directors

Managing partners,
Road & Logistics
companies

Managing
partners, Air &
Ocean companies

Heads
of Group
Functions

Board of directors Board of directors Board of directors



Morten Mathiesen
Chairman of the Board
Member since: 2012
Born: 1975



Jørgen Hansen
Vice chairman of the Board
Member since: 2011
Born: 1960



Michael Larsen
Board member
Member since: 2019
Born: 1976



Finn Skovbo Pedersen
Board member
Member since: 2018
Born: 1955

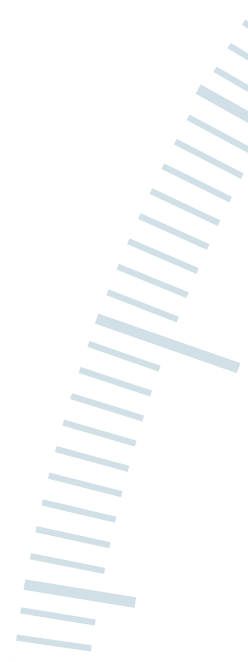



Peter Grubert

Board member

Member since: 2014

Born: 1963



Stefan Pettersson

Board member

Member since: 2013

Born: 1970



Ulrik Ross

Board member

Member since: 2018

Born: 1971

Executive Board



We are open-minded and make a difference for our customers.

Jesper E. Petersen

Group CEO, Road & Logistics

Mr Petersen joined NTG in 2016 as Group CEO of NTG's Road & Logistics Division. He has more than 40 years' experience within freight forwarding and has previously held senior management positions within other large companies in the industry, including European leadership positions. During his career he has worked and lived in Italy and Germany for a total of 15 years.

In addition to vast industry experience, Mr Petersen brings an entrepreneurial mind-set, having built, led, and successfully exited a freight forwarding company in Italy.

Mr Petersen is the President of the Danish Freight Forwarders Association.



Every challenge is a chance for success.

Mikkel Fruergaard

Group CEO, Air & Ocean

Mr Fruergaard joined NTG in 2016 as Group CEO and was responsible for the Air & Ocean and Projects divisions. Since then he has played a key role in NTG's international expansion and growth.

Mr Fruergaard is a former First Lieutenant of the Royal Danish Army, and a graduate of the Maersk International Shipping School. For the past 20 years he has worked for some of the largest players in the shipping industry, both in Denmark and abroad.

Mr Fruergaard brings extensive experience of working for public and private companies and is skilled in M&A, restructuring, customer relations and leading diverse teams across the globe.

Mr Fruergaard has completed various executive training programs and holds an MBA (Hons) from IMD Business School in Switzerland.



Standardisation and measurement are fundamental to good management.

Christian D. Jakobsen

Group CFO

Mr Jakobsen joined NTG in 2018 as Group CFO.

He has more than 20 years' experience within finance, accounting, and freight forwarding, and has previously held several senior financial positions within the transport industry, both in Denmark and abroad.

Mr Jakobsen spent 8 years in Germany in a managing position.

Mr Jakobsen has extensive experience of integrating companies and is skilled in M&A, restructuring and process optimisation.

Mr Jakobsen has a background as a Big Four auditor, bringing extensive experience of working for both large private and publicly listed companies.

Risk Management

The goal of Risk Management within NTG is to reduce business risks and financial risks to a satisfactory level for stakeholders of the Group. The process of identifying and mitigating risks is based upon extensive managerial experience within the freight forwarding industry, combined with a strong back-office focus on compliance and capital structure.

NTG's governance model supports the Groups' risk management strategy by implementing short lines of communication and cultivating the ability to adapt to shifting market situations. Adaptability and managerial involvement are crucial in creating value from the risks faced by the Group.

The Executive Board is responsible for NTG's internal risk management process, and functions as the prime driver of risk identification and mitigation. Identified risks with a pervasive effect for the Group are handled in close collaboration with the Board of Directors.

Macroeconomic risk

Freight forwarding is highly dependent on the global economy and NTG's business will be affected by movements in the macroeconomic environments to which the Group is exposed. The Group addresses this risk by maintaining a sharp focus on cost optimisation, organisational flexibility and maintaining a low base of fixed costs. Historically, NTG has delivered far-above-average profit margins, which help to secure the bottom line. This strategy is supported by keeping a close eye on business opportunities available in both current and new markets.

Commodity risk

As a supply chain company, NTG is exposed to the risk of increase in input-factor prices, primarily the price of fuel. Due to the inherent setup of the Group's business model, NTG has proven an ability to mitigate the effects of price increases without major delays. Residual risk is immaterial to the Group, and as such fuel prices are not hedged.

Currency risks

An international transport group such as NTG carries out transactions in several currencies, thereby exposing the Group's cash flows to a certain currency risk. Operational cash flows in the Group are, however, short term in nature, with

outflows to a large extent being matched by the corresponding inflows. The resulting currency effect on outstanding balances is thereby limited to a net position in the given foreign currencies. Operational cash flows are generally not hedged, as the cost of hedging would exceed the value created by entering currency contracts with the Group's current exposure in mind.

Equity positions in foreign currencies are limited by keeping a lean balance sheet in the Group's subsidiaries and utilising inter-group treasury accounts.

Credit and financing risks

NTG's credit risk is mainly related to future cash flows from customers. By maintaining an organisational culture of local ownership and individual accountability, the Group's customer-facing personnel monitor individual customer solvency on a recurring basis and respond to indications of credit deterioration promptly. Close monitoring of customers and quick responses to changes in market situations have led to a very low historical credit loss within the Group. NTG does not employ credit insurance, as the benefits do not outweigh the costs when considering the Group's current customer mix.

Our goal is to maintain a capital structure with a low degree of leveraging, thus limiting the risk related to the financing of the Group's activities to a negligible level.

Disruption

In 2018, NTG made the decision to implement a modern Transport Management System for the Air & Ocean division, which we believe is among the best in the industry. NTG is of course subject to the risk that liners will try to insource more of the volumes, but since we do not have customers with a lot of boxes, we believe we will be less affected compared to the market as a whole.



NTG's governance model supports the risk management strategy by implementing short lines of communication and cultivating the ability to adapt quickly to shifting market situations.

Lofoten Hormuz
Malacca strait
Øresund

We take our Corporate Social Responsibility seriously

Commercial freight forwarding constitutes the key activities of NTG. Operations are carried out at locations throughout Europe, Asia and the US.

The Group is a partnership constituted by more than 80 companies, in which the ownership of individual companies in the Group is shared between the parent company, local management and employees in partner companies. The parent company is a majority shareholder in all partner companies.

NTG employs 1.300 persons, of which the vast majority are administrative office-based workers deployed in the planning and booking of freight forwarding.

CSR-related risk analysis

NTG's potential risk of influencing the environment, social- and employee relationships, human rights and anti-corruption is estimated to be limited, as compared to non-CSR related risk. Risk is seen as a combination of the impact and likelihood of any given subject.

Environmental policies

NTG has identified three areas which require attention in relation to environmental and climate related risk:

- Energy consumption at own facilities.
- Paper usage in handling freight orders.
- Fuel consumption and emissions of transportation of subcontracted transport and vehicle idling.

NTG wishes to continuously improve the organisation's environmental impact. The company is committed to complying with relevant environmentally-oriented legislation. NTG is in the process of aligning all work in relation to the environment and climate with the ISO 14001 requirements. NTG's environmental policies are formalised in the Quality and Environmental Manual.

Our efforts and results

In August 2018, NTG obtained both ISO 14001 and ISO 9001 certifications in many of the Group's subsidiaries and thus concluded two years of effort. In 2018 the company continued its effort to install light-regulating sensors throughout NTG

facilities, and to replace all lighting with LED sources. The results for 2018, measured as kWh pr. headcount, were satisfying, and the company retains its ambition to further reduce the use of electrical equipment and resources.

NTG has continued efforts to minimise consumption of paper, and thus help to reduce deforestation. NTG has done so primarily by reducing printing through smarter IT solutions and by placing a significant focus on awareness of paper product-related issues, which has led to a satisfying decrease in paper usage.

In order to minimise fuel consumption-related emissions, over the course of 2018 NTG completed the replacement of gas-driven forklifts with electrical ones. Furthermore, NTG Group has reached a Euro Norm (diesel engine efficiency norm) score average just short of 6, higher than the target average of 5. NTG will continue to focus on diesel engine efficiency by making inquiries about the Euro Norm scores of subcontractors' vehicle fleets, in order to ensure a continuous improvement among subcontractors throughout Europe. When engaging in activities with new contractors, the company maintains the Euro Norm score as a decision criterion, which was used in 2018 to choose among partnerships.

Our employees mean everything

The Group's most important asset is its employees, who strive to solve and exceed customers' needs, requirements and expectations. The company is dependent on having satisfied employees who can perform their job in a safe and productive environment. These ambitions are reflected in the objectives of NTG.

In cooperation with its sub-contractors, NTG conducts road safety initiatives that are continuously evaluated and improved. NTG strictly prohibits driving while under the influence of alcohol, drugs, and pharmaceuticals or while fatigued. Furthermore, compliance is required with the existing regulations regarding driving and rest time for employees who drive heavy vehicles.

Efforts and results

In order to monitor employee satisfaction, NTG conducts yearly employee satisfaction surveys. Furthermore, NTG presents the results of the surveys to employees, in order to identify sources of dissatisfaction not illustrated by or addressed in the survey. The company encourages all employees to act upon any instance of dissatisfaction, with either the survey results or the workplace in general, in order to continuously improve working conditions for employees. In 2018, NTG was able to reach a satisfying employee satisfaction score, which reflects that of the sector.



Human rights policies

The Group acknowledges and supports the maintenance of internationally declared human rights and bases its work on the UN's universal declaration on human rights and interprets this as the responsibility of the state to protect, and of companies to respect these rights.

NTG does not discriminate and prohibits any discrimination based on race, colour, religion, gender, age, nationality, sexual orientation, disability, political observation, social background or any status protected by the law. NTG condemns all forms of forced labour and all exploitative working conditions and does

not employ or cooperate with entities that employ persons under the legal working age. Policies regarding human rights are clarified in the NTG's code of conduct.

Code of conduct

Throughout 2018 NTG continued to actively promote values inherent to the code of conduct, such as, but not limited to, diversity, among partner companies. Since operations commenced, NTG has terminated collaborations with haulers due to code of conduct related non-conformities. Such terminations of cooperation also took place in 2018.

Anti-corruption policies

The Group does not accept corruption in any form and the company is committed to preventing the occurrence of corruption or bribes to any person, whether private, public, direct or indirect. NTG recognises that facilitation payments are bribes, and as such NTG is committed to working to identify and eliminate them. The Group is committed to complying with relevant legislation concerning anti-corruption and to introducing the required standards. Policies regarding anti-corruption are clarified in NTG's code of conduct.

Efforts and results concerning anti-corruption

In 2018 NTG continued to distribute its code of conduct to new and existing partners. As a result, partners within the Group have communicated the company's policies and values in relation to anti-corruption and bribery to sub-contractors and customers, both in order to ensure compliant behaviour and to represent NTG's efforts to prevent corruption.

NTG has not identified any cases where the company's policies in relation to anti-corruption and bribery were violated during 2018.

Account of NTG's gender composition

NTG is committed to ensuring that all employees have the best opportunities to create a career in the Group. Our employees are our the key to our success. Group Management does not discriminate on the basis of gender but wants to employ the best candidate for the job in question. Management is aware that the transport industry is an area that attracts men to a higher degree than women, which obviously affects gender representation. However, to ensure continued access to a broad range of employees and skills, it is management's objective to try to increase the share of women on both the management team and in the organisation generally.

The share of female employees in the Group was 36 % in 2018, whereas the share of female executives was below 20 %. It is a central element of NTG's HR policy that its female employees should have the same career and executive promotion options as male employees.

The Group has a target of 1/7 representation of the underrepresented gender on the Board of Directors, which is expected to be reached by 2022 at the latest. The target has not yet been reached as, at the end of 2018, all board members were men. The time horizon is based on the Company's current Board of Directors has the skills and composition that the

Group's strategic developments currently requires. It is the policy of the Group to always appoint the best qualified candidates to leadership posts and at the same time support and enhance the qualifications of female leadership talents.

In connection with ongoing changes in the Board of Directors, the objective of representation of the underrepresented gender in the Board will be pursued by specifically focusing on identifying and considering female candidates in the process.



NTG wishes to continuously improve the organization's environmental impact.

Financial Statements

Table of content

Income statement	38
Statement of comprehensive income	38
Cash flow statement	39
Balance sheet	40
Statement of changes in equity	41
Notes to the financial statements	43

NTG A/S
shareholders'
share of equity

Non-
controlling
interests

Total equity

91.869

65.696

157.565

42.407

69.116

111.523

-5.697

-681

-6.378

3.175

0

3.175³⁷

0

0

Income Statement

(DKK '000)	Note	2018	2017
Net revenue	2.2	4.512.137	2.896.181
Direct costs	2.3	-3.635.529	-2.350.217
Gross profit		876.608	545.964
Other external expenses	2.4	-204.451	-141.375
Staff costs	2.5	-475.335	-244.334
Operating profit before amortisations, depreciations and special items		196.822	160.255
Amortisations and depreciation of intangible and tangible fixed assets	2.7	-7.666	-2.666
Operating profit before special items		189.156	157.589
Special items, net	2.6	-17.563	-1.161
Financial income	2.8	1.741	1.112
Financial costs	2.8	-16.513	-8.846
Profit before tax		156.821	148.694
Tax on profit for the year	3.1	-45.298	-37.234
Profit for the year		111.523	111.460
Attributable to:			
Shareholders in NTG A/S		42.407	58.886
Non-controlling interests		69.116	52.574
Earnings per share			
Earnings per share (DKK)	6.2	81	115

Statement of Comprehensive Income

(DKK '000)	Note	2018	2017
Profit for the year		111.523	111.460
<i>Items that may be reclassified to the income statement:</i>			
Foreign exchange adjustments of subsidiaries		-6.378	297
<i>Items will not be reclassified to the income statement:</i>			
Actuarial adjustments on retirement benefit obligations	8.1	3.175	0
Other comprehensive income		-3.203	297
Total comprehensive income		108.320	111.757
Attributable to:			
Shareholders in NTG A/S		39.885	58.545
Non-controlling interests		68.435	53.212

Cash Flow Statement

(DKK '000)	Note	2018	2017	(DKK '000)	Note	2018	2017
Operating profit before special items		189.156	157.589	Cash and cash equivalents at 1 January		175.907	177.092
Depreciation and amortisations		7.666	2.666	Cash flow for the year		-11.106	-1.481
Change in working capital etc.		2.334	-54.007	Currency translation adjustments		-6.813	296
Change in provisions		-6.439	0	Cash and cash equivalents at 31 December		157.988	175.907
Financial income received		1.741	1.112				
Financial expenses paid		-16.513	-8.237				
Corporation taxes paid		-44.522	-15.183				
Special items		-16.063	-1.161				
Cash flow from operating activities		117.360	82.779				
Purchase of intangible assets		-1.035	-3.104				
Purchase of property, plant and equipment		-17.897	-2.609				
Disposal of tangible assets		1.303	0				
Acquisition of business activities	7.1	-1.485	-30.936				
Changes in other financial assets		-499	110				
Cash flow from investing activities		-19.613	-36.539				
Free cash flow		97.747	46.240				
Repayment of loans		-67.355	-7.729				
Proceeds from loans		22.823	2.023				
Proceeds and repayments of other financial liabilities		-397	725				
<i>Shareholders and non-controlling interests</i>							
Proceeds from issue of share capital		0	328				
Dividends paid to non-controlling interests		-51.078	-41.826				
Changes in non-controlling interests		-12.846	-1.242				
Cash flow from financing activities		-108.853	-47.721				
Cash flow for the year		-11.106	-1.481				

* The cash and cash equivalents disclosed in the statement of cash flows include DKK 31.408 thousand which are held on restricted deposit accounts

Balance Sheet

Assets

(DKK '000)	Note	2018	2017	2016
Intangible assets	5.1	331.057	90.769	51.902
Property, plant and equipment	5.2	58.544	14.604	3.567
Other receivables	4.2	8.906	450	560
Deferred tax assets	3.2	4.470	139	346
Total non-current assets		402.977	105.962	56.375
Trade receivables	4.1	729.084	443.172	311.462
Other receivables	4.2	83.146	44.121	13.171
Cash and cash equivalents	4.3	157.988	175.907	177.092
Corporation tax		117	2.219	76
Total current assets		970.335	665.419	501.801
Total assets		1.373.312	771.381	558.176

Equity and Liabilities

(DKK '000)	Note	2018	2017	2016
Share capital	6.1	526	520	500
Reserves		113.483	91.349	38.353
NTG A/S shareholders' share of equity		114.009	91.869	38.853
Non-controlling interests	7.2	93.898	65.696	36.747
Total equity		207.907	157.565	75.600
Deferred tax liabilities	3.2	2.892	325	0
Pensions and similar obligations	8.1	135.157	0	0
Provisions	5.3	48.697	9.428	7.500
Financial liabilities	4.5	18.167	4.505	0
Total non-current liabilities		204.913	14.258	7.500
Provisions	5.3	65.502	2.000	2.000
Financial liabilities	4.5	50.346	74.942	65.875
Trade payables	4.4	693.362	427.676	321.359
Other payables	4.4	113.168	59.617	74.712
Corporation tax		38.114	35.323	11.130
Total current liabilities		960.492	599.558	475.076
Total liabilities		1.165.405	613.816	482.576
Total equity and liabilities		1.373.312	771.381	558.176

Statement of Changes in Equity

2018

(DKK '000)	Share capital	Share premium	Translation reserve	Retained earnings	NTGA/S shareholders' share of equity	Non-controlling interests	Total equity
Equity at 1 January	520	0	-341	91.690	91.869	65.696	157.565
Profit for the year	0	0	0	42.407	42.407	69.116	111.523
Net exchange differences recognized in OCI	0	0	-5.697	0	-5.697	-681	-6.378
Actuarial gains/(losses)	0	0	0	3.175	3.175	0	3.175
Tax on other comprehensive income	0	0	0	0	0	0	0
Other comprehensive income, net of tax	0	0	-5.697	3.175	-2.522	-681	-3.203
Total comprehensive income for the year	0	0	-5.697	45.582	39.885	68.435	108.320
<i>Transactions with shareholders:</i>							
Dividends distributed	0	0	0	0	0	-51.078	-51.078
Purchase of treasury shares	0	0	0	0	0	0	0
Capital increase	0	0	0	0	0	0	0
Net addition of non-controlling interests	6	6.934	0	-24.685	-17.745	10.845	-6.900
Other adjustments	0	-6.934	0	6.934	0	0	0
Total transactions with owners	6	0	0	-17.751	-17.745	-40.233	-57.978
Equity at 31 December	526	0	-6.038	119.521	114.009	93.898	207.907

Statement of Changes in Equity

2017

(DKK '000)	Share capital	Share premium	Translation reserve	Retained earnings	NTGA/S shareholders' share of equity	Non-controlling interests	Total equity
Equity at 1 January	500	0	0	38.354	38.854	36.747	75.601
Profit for the year	0	0	0	58.886	58.886	52.574	111.460
Net exchange differences recognized in OCI	0	0	-341	0	-341	638	297
Actuarial gains/(losses)	0	0	0	0	0	0	0
Tax on other comprehensive income	0	0	0	0	0	0	0
Other comprehensive income, net of tax	0	0	-341	0	-341	638	297
Total comprehensive income for the year	0	0	-341	58.886	58.545	53.212	111.757
Transactions with shareholders:							
Dividends distributed	0	0	0	0	0	-41.826	-41.826
Purchase of treasury shares	0	0	0	0	0	-1.242	-1.242
Capital increase	20	308	0	0	328	0	328
Net addition of non-controlling interests	0	0	0	-5.858	-5.858	18.805	12.947
Other adjustments	0	-308	0	308	0	0	0
Total transactions with owners	20	0	0	-5.550	-5.530	-24.263	-29.793
Equity at 31 December	520	0	-341	91.690	91.869	65.696	157.565

Notes to the consolidated financial statements

Table of contents

1. BASIS FOR PREPARATION		5. NON-FINANCIAL ASSETS AND LIABILITIES	
1.1. Accounting policies, estimates and judgements	44	5.1. Intangible assets	56
1.2. First time adoption of IFRS	46	5.2. Tangible assets and fixed investments	58
		5.3. Provisions	59
2. PROFIT FOR THE YEAR		6. CAPITAL AND FINANCIAL RISKS	
2.1. Segment information	48	6.1. Equity	60
2.2. Net revenue	49	6.2. Earnings per share	60
2.3. Direct costs	49	6.3. Capital Management	60
2.4. Other external expenses	50	6.4. Financial risks	60
2.5. Staff costs	50		
2.6. Special items	50	7. COMPOSITION OF THE GROUP	
2.7. Amortisation and depreciation for the year	51	7.1. Acquisition and disposal of entities	63
2.8. Financial income and expenses	51	7.2. Non-controlling interest	65
		8. OTHER DISCLOSURES	
3. TAX		8.1. Pension obligations	67
3.1. Income tax	52	8.2. Leases	69
3.2. Deferred tax	52	8.3. Fees to auditors appointed at the Annual general meeting	69
		8.4. Related party transactions	70
4. FINANCIAL ASSETS AND LIABILITIES		8.5. Commitments and contingent liabilities	70
4.1. Receivables	54	8.6. Events after the reporting period	70
4.2. Other receivables	54		
4.3. Cash and cash equivalents	54		
4.4. Trade and other payables	55		
4.5. Other financial liabilities	55		

1. Basis for preparation

This section provides an overview of the financial accounting policies and key accounting estimates applied in the preparation of the Group's financial statements. The accounting policies set out in section 1.1. below have been applied consistently with respect to the financial year and comparative figures from previous year.

This Annual Report is the Group's first Annual Report presented in accordance with IFRS. Section 1.2 describes the accounting consequences of adopting IFRS and relevant transition considerations.

The Annual Report for 2018 was approved by the Executive Management and the Board of Directors on 4 April 2019 and will be presented for approval at the subsequent Annual General Meeting on 4 April 2019.

1.1. Accounting policies, estimates and judgements

The Annual Report for the period 1 January - 31 December 2018 comprise the consolidated financial statements of the

parent company Nordic Transport Group A/S and subsidiaries controlled by the parent company (the Group).

The annual report has been prepared on a going concern basis and in accordance with the historical cost convention, except where IFRS explicitly requires use of other values.

Application of new reporting standards

The Group has implemented all new EU-approved standards and interpretations effective to the financial year 2018. IASB has issued a number of new standards and amendments which have not yet taken effect. Of these standards, the Group only expects IFRS 16 and IFRIC 23 to have a material impact on the consolidated financial statements at the time of implementation. The Group has chosen to pre-implement IFRIC 23 according to the retrospective approach in connection with the first-time adoption of IFRS at 1 January 2017 following the most likely amount method. Refer to note 1.2 for an assessment of the impact.

IFRS 16 "Leasing" was issued in January 2016. In 2017, it was endorsed by the EU. It will result in almost all leases being recognised on the balance sheet, as the distinction between operating and finance leases is removed. Under the new standard, an asset (the right to use the leased item) and a financial liability to pay rentals are recognised in the balance sheet.

The only exceptions are short-term and low-value leases. The Group will make use of the relief options provided for leases of low-value assets and short-term leases. The standard is effective for annual periods beginning on or after 1 January 2019 and earlier application is permitted. The Group will implement this standard when it takes effect. The standard will be implemented following the modified retrospective approach.

The Group has concluded initial analyses of the impending changes resulting from IFRS 16. This preliminary estimate show that right-of-use assets and corresponding liabilities will amount to DKK 705 - 775 million at initial application with no effect on equity.

The impact of the income statement in 2019 is estimated to be a reduction in rental costs of DKK 155 - 170 million and an increase in amortisation costs of DKK 145 - 155 million. Impact on interest expense is expected to be approximately DKK 16 million.

No other new standards or interpretations are expected to have significant impact on the financial statements of the Group.

Consolidation principles

The Consolidated financial statements comprise Nordic Transport Group A/S (Parent Company) and its subsidiaries.

Subsidiaries are all entities over which the Group has control. The Group controls an entity when the Group is exposed to, or has rights to, variable returns from its involvement with the entity and has the ability to affect those returns through its power to direct the activities of the entity. Subsidiaries are fully consolidated from the date on which control is transferred to the Group. They are deconsolidated from the date that control ceases.

The acquisition method of accounting is used to account for business combinations by the Group (refer to note 7.1).

Consolidation is performed by summarizing the financial statements of the Parent Company and its subsidiaries. Intercompany transactions, balances and unrealized gains on transactions between Group entities are eliminated. Unrealized losses are also eliminated unless the transaction provides evidence of an impairment of the transferred asset. Accounting policies of subsidiaries have been changed where necessary to ensure consistency with the policies adopted by the Group.

Non-controlling interests' share of profit/loss for the year and of equity in subsidiaries is included the Group's profit/loss for the year and of the equity of subsidiaries, respectively, but shown as separate items.

Associates are all entities over which the Group has significant influence, but not control or joint control. This is generally the case when the Group holds between 20% and 50% of the voting rights. Investments in associates are accounted for using the equity method of accounting, after initially being recognised at cost.

Recently acquired or sold subsidiaries are recognised in the consolidated income statement for the period in which the Parent controls such entities.

Foreign currency translation

Functional and presentation currency

Items in the financial statements of each reporting entity of the Group are measured in the currency of the primary economic environment in which the entity operates (the functional currency).

The functional currency of the Parent Company, Nordic Transport Group A/S is DKK.

The financial statements are presented in Danish kroner (DKK), and all amounts have been rounded to the nearest thousand.

Transactions and balances

Foreign currency transactions are translated into the functional currency using the exchange rates at the dates of

the transactions. Foreign exchange gains and losses resulting from the settlement of such transactions and from the translation of monetary assets and liabilities denominated in foreign currencies at year end exchange rates are generally recognised on a net basis in the statement of profit or loss, within financial items.

Group entities

The results and financial position of all Group entities that have a functional currency different from the presentation currency are translated into the presentation currency as follows:

- a) Assets and liabilities for each entity's balance sheet are translated at the closing rate at the date of that balance sheet;
- b) Income and expenses for each entity's income statement are translated at average exchange rates; and
- c) All resulting exchange differences are recognized directly in other comprehensive income.

Goodwill and fair value adjustments arising on the acquisition of a foreign entity are treated as assets and liabilities of the foreign entity and translated at the closing rate. Exchange differences arising are recognized in other comprehensive income.

Statement of cash flow

The cash flow statement shows the Group's cash flows during the year distributed on operating, investing and financing activities, including changes in cash and cash equivalents at the beginning and at the end of the year. The cash flow statement cannot be derived directly from the balance sheet and income statement.

Cash flows from operating activities are calculated using the indirect method and as operating profit before special items (adj. EBIT) for the year adjusted for changes in working capital and non-cash operating items such as depreciation, amortisation and impairment losses, and provisions. Working capital comprises current assets less short-term debt excluding items included in cash and cash equivalents.

Cash flows from investing activities comprise cash flows from acquisitions and disposals of intangible assets, property, plant and equipment as well as fixed asset investments.

Cash flows from financing activities comprise cash flows from the raising and repayment of long-term debt as well as payments to and from shareholders.

Cash and cash equivalents consist of cash at bank and in hand less current bank loans due on demand.

Materiality

The financial statements separately present items which are considered individually material. Individually immaterial

items are aggregated with other items of similar nature in the statements or in the notes. All required disclosures by IFRS are presented, unless the information is considered immaterial to the economic decision making of the users of the financial statements.

Accounting estimates and judgements

The Group makes estimates and assumptions concerning the future. The resulting accounting estimates rely on Management judgement and will, by definition, seldom equal the related actual results.

Estimates and assumptions made are based on historical experience and other factors that Management considers to be reliable, but which by their very nature are associated with uncertainty and unpredictability. These assumptions may prove incomplete or incorrect, and unexpected events or circumstances may arise. The estimates and assumptions deemed most significant to the preparation of the consolidated financial statements are addressed below:

- Acquisition of enterprises (Note 7.1)
- Defined benefit pension plans (Note 8.1)

Refer to each of the specific notes for details on relevant accounting policies and further description of significant estimates and assumptions used.

Risk factors specific to the Group are described in the management report from pages 32-33 and in note 6.4.

1.2 First time adoption of IFRS

For all periods up to and including the year ended 31 December 2017, the Group prepared its financial statements in accordance with Danish Financial Statement Act. These financial statements, for the year ended 31 December 2018, are the first of the Group's financial statements prepared in accordance with International Financial Reporting Standards (IFRS) as adopted by the EU and additional requirements in the Danish Financial Statements Act.

The Group has adopted IFRS for its consolidated financial statements with effect from 1 January 2017. The comparative figures for 2017 were restated in accordance with IFRS. Transition-effects on comparative figures are summarized below.

Exemptions applied

IFRS 1 allows first-time adopters certain exemptions from the retrospective application of some requirements under IFRS.

The Group has applied the following exemptions:

- IFRS 3 Business Combinations has not been applied to business acquisitions that occurred before 1 January 2017. Use of this exemption means that Local GAAP carrying amounts of assets and liabilities, which are required to be recognised under IFRS, is their deemed cost at the date of the acquisition. After the date of adoption to IFRS the measurement is in accordance with IFRS. Assets and liabilities that do not qualify for recognition under IFRS are excluded from the opening IFRS statement of financial position. The Group did

not recognise or exclude any previously recognised amounts as a result of IFRS recognition requirements. IFRS 1 also requires that the Local GAAP carrying amount of goodwill must be used in the opening IFRS statement of financial position (apart from adjustments for goodwill impairment and recognition or derecognition of intangible assets). In accordance with IFRS 1, the Group has tested goodwill for impairment at the date of transition to IFRS. No goodwill impairment was deemed necessary at 1 January 2017.

- Cumulative currency translation differences for all foreign operations are deemed to be zero as at 1 January 2017.

Accounting effects

The accounting effect of the Group's transition to IFRS were limited to:

- Reversal of amortisations on goodwill for 2017, as goodwill is not amortized according to IFRS,
- Implementation of an expected credit loss model to reflect the Group's credit risk towards trade receivables, cf. IFRS 9, and
- Review of the Group's tax positions according to the provisions in IFRIC 23.

In addition to the above-mentioned transition differences, a few individually immaterial adjustments were needed to ensure presentation of the Group's comparative figures in accordance with IFRS.

The conversion to IFRS has not had any significant effect on the cash flow statement, and therefore no reconciliation of the cash flow statement has been prepared.

	1/1 2017		2017		31/12 2017
(DKK '000)	Equity	Profit for the year	Other comprehensive income	Transactions with owners	Equity
Danish Financial Statements Act	88.200	111.546	297	-23.936	176.107
<i>Related to changes in accounting practice:</i>					
Goodwill amortisation cf. IFRS 3	0	4.978	0	0	4.978
Provision on trade receivables cf. IFRS 9	-1.232	337	0	0	-895
Tax positions cf. IFRIC 23	-9.500	-1.928	0	0	-11.428
Other adjustments	-1.868	-3.473	0	-5.856	-11.197
Total adjustments	-12.600	-86	0	-5.857	-18.542
According to IFRS	75.600	111.460	297	-29.792	157.565

2. Profit for the year

This section includes disclosures on components of consolidated profit for the year.

2.1 Segment information

Accounting policies

The Management monitors the operating results of its business units separately for the purpose of making decisions about resource allocation and performance assessment. Segment performance is evaluated based on operating profit or loss before special items and is measured consistently with operating profit or loss in the consolidated statement of income.

Operating segments

The Group's business operations are carried out by two divisions, forming the basis for the Group's segment reporting. Information on business segments is based on the Group's risk and returns and its internal financial reporting system. The segmentation is a direct match to the Group's management structure, with a responsible CEO for each of the two operating segments. Business segments are regarded as the primary segments. Items related to Head-office functions are not part of the business segments and are as such separated in the segment reporting. All intersegment transactions and settlements are carried out on an arm's length basis.

Air & Ocean

The Air & Ocean division provides international air and ocean freight services, including project transports.

Road & Logistics

The Road & Logistics division provides transport and warehousing solutions with a geographical focus on Europe.

Major customers

The Group has no customers contributing revenue of more than 10 % of total revenue and the Group is therefore not reliant on any major customers.

(DKK '000)	Road & Logistics		Air & Ocean		Eliminations etc.		Total	
	2018	2017	2018	2017	2018	2017	2018	2017
Segment revenue	3.662.781	2.500.303	875.840	412.490	50.446	44.068	4.589.067	2.956.861
Revenue (Intercompany)	-22.145	-15.117	-4.477	-2.109	-50.308	-43.454	-76.930	-60.680
Revenue (external)	3.640.636	2.485.186	871.363	410.381	139	614	4.512.137	2.896.181
Gross Profit	650.533	445.682	225.941	98.971	135	1.311	876.608	545.964
Amortisation and depreciations	7.283	2.613	383	53		0	7.666	2.666
Operating profit before special items	170.871	144.752	14.912	11.909	3.373	927	189.156	157.589

*Total assets and liabilities for each segment is not reported because such amounts are not regularly provided to the CODM.

The following tables present information regarding the Group's geographical segments on revenue and non-current assets, both of which are allocated according to the country in which the individual consolidated entity is based.

Net revenue		
(DKK '000)	2018	2017
Denmark	1.722.038	1.421.810
Sweden	766.488	634.939
Germany	602.380	93.070
Finland	516.781	499.308
Other	904.450	247.053
Total	4.512.137	2.896.181

Non-current asset		
(DKK '000)	2018	2017
Denmark	322.924	80.117
Sweden	1.377	-351
Germany	21.732	3.724
Finland	13.669	14.752
Other	38.805	7.581
Total	398.507	105.823

*Non-current assets less tax assets

2.2 Net revenue

Accounting policies

The Group derives revenue mainly from freight forwarding services related to transport of goods throughout Europe and worldwide by road, ocean and air.

Revenue from contracts with customers is recognized when control of freight forwarding services are transferred to the customer at an amount that reflects the consideration to which the Group expects to be entitled in exchange for those services. Freight forwarding services and other services are generally characterized by short delivery times except for sea services that takes longer due to the nature of the service delivered.

Timing of revenue recognition reflects when fulfilment of performance obligations towards customers take place and follows the over-time principle because the customer receives and uses the benefits simultaneously.

When determining the transaction price for the sale of services, the Group considers the effect of variable consideration and any other significant factors affecting the transaction price. The Group's ordinary course of business is to agree a price (transaction price) with the customer for performing the specific service (price allocation) before booking a haulier/ carrier and delivering the service. No material effect of variable consideration is present, and no material uncertainty is therefore associated with the contract price on an individual transport level. No significant financing component is included

in the transaction price, as all sales are made with credit terms between 14-60 days from the delivery date, in coherence with market practice. Consequently, no adjustments to the transaction prices for the time value of money is carried out.

Estimates of revenues, costs or extent of progress toward completion are revised if circumstances change. Any resulting increases or decreases in estimated revenues or costs are reflected in profit or loss in the period in which the circumstances that give rise to the revision become known by management. Change of circumstances relating to individual transports will ordinarily have a non-material effect on the Group's consolidated revenue.

Accrued revenue and accrued costs of services in progress at 31 December 2018 are presented as deferred revenue and costs related to deferred revenue. Accrued revenue is estimated and recognized when a sales transaction fulfils the criteria for revenue recognition, but no final invoice has yet been issued to the customer at the end of the reporting period. Accrued costs are estimated and recognized when supplier invoices relating to recognized revenue for the reporting period have yet to be received.

2.3 Direct costs

Accounting policies

Direct costs comprise costs incurred to achieve the year's revenue and primarily includes costs for hauliers, shipping companies and airlines.

2.4 Other external expenses

Accounting policies

Other external expenses include expenses related to rent, IT, training and education, travelling and other costs for operations and maintenance.

2.5 Staff costs

Accounting policies

Staff costs include salaries, bonuses, pensions, social security costs, vacation pay and other benefits.

Staff costs are recognised in the financial year in which the associated services are rendered by the employees. Costs related to long-term employee benefits, e.g. defined benefit pension plans, are recognized in the periods in which they are earned.

Please refer to note 8.1 for information on the Group's pension plans, including description of accounting principles.

(DKK '000)	2018	2017
Wages and salaries	392.008	204.780
Defined contribution pension plans	25.443	16.488
Defined benefit pension plans	3.826	0
Other social security costs	40.859	15.736
Other staff costs	13.199	7.330
Total staff costs	475.335	244.334
Average full time employees	1.349	734
Number of full-time employees at year-end	1.335	741

Remuneration to the Executive management Board and the Board of Directors are given below:

(DKK '000)	2018
Wages and salaries	350
Board of Directors	350

Remuneration to the Board of Directors amounts to 0 DKK in 2017.

(DKK '000)	2018	2017
Wages and salaries	6.368	2.957
Pension, defined contribution plans	1.120	93
Other social costs	14	10
Executive Management Board total	7.502	3.060

2.6 Special items

Accounting policies

Special items are reported in the profit or loss for the year and comprise significant income and expenses of an exceptional nature relative to the Group's ordinary operations or costs related to investments in future activities.

The items are stated separately to give a true and fair view of the Group's operating profit.

Special items for the year comprise:

- Transaction and integration costs from business combinations
- Other costs not related to the Groups ordinary course of business

(DKK '000)	2018	2017
Transaction and integration costs from business combinations	15.206	1.161
Other costs	2.357	0
Total	17.563	1.161

Special item line reconciliation:

(DKK '000)	2018			2017		
	Reported income statement	Special Items	Adjusted income statement	Reported income statement	Special Items	Adjusted income statement
Net revenue	4.512.137	0	4.512.137	2.896.181	0	2.896.181
Direct costs	-3.635.529	0	-3.635.529	-2.350.217	0	-2.350.217
Gross profit	876.608	0	876.608	545.964	0	545.964
Other external expenses	-204.451	-11.737	-216.188	-141.375	-1.161	-142.536
Staff costs	-475.335	-5.826	-481.161	-244.334	0	-244.334
Operating profit before amortisation and depreciation	196.822	-17.563	179.259	160.255	-1.161	159.094
Amortisation and depreciation	-7.666	0	-7.666	-2.666	0	-2.666
Operating profit	189.156	-17.563	171.592	157.589	-1.161	156.428
Special items costs	-17.563	17.563	0	-1.161	1.161	0
Financial income	1.741	0	1.741	1.112	0	1.112
Financial expenses	-16.513	0	-16.513	-8.846	0	-8.846
Profit before tax	156.821	0	156.821	148.694	0	148.694

2.7 Amortisation and depreciation for the year

Accounting policies

Amortisation and depreciation relate to intangible assets and property, plant and equipment and is based on the profiles on the underlying asset (see notes 5.1 and 5.2)

(DKK '000)	2018	2017
Amortisation of intangible assets	-401	0
Depreciation of tangible assets	-7.265	2.666
Total	-7.666	2.666

2.8 Financial income and expenses

Accounting policies

Financial income and expenses comprise interest income and expenses, realised and non-realised capital gains/losses on transactions in foreign currency, amortisation of financial assets and liabilities etc.

Financial income (DKK '000)	2018	2017
Interest income	1.207	171
Other financial income	534	941
Total	1.741	1.112

Financial expense (DKK '000)

	2018	2017
Interest expense	2.396	2.276
Calculated interest on pensions plan (note 8.1)	1.812	0
Exchange differences	6.224	3.073
Other financial expenses	6.080	3.497
Total	16.513	8.846

3. Tax

This section contains relevant disclosures and details regarding tax recognized in the financial statements. The total tax on Group profit for the year amounts to DKK 45.298 thousand.

3.1 Income tax

Accounting policies

The income tax expense or credit for the period is the tax payable on the current period's taxable income based on the applicable income tax rate for each jurisdiction adjusted by changes in deferred tax assets and liabilities attributable to temporary differences and to unused tax losses.

The current income tax charge is calculated on the basis of the tax laws enacted or substantively enacted at the balance sheet date in the countries where the Group operates and generates taxable income. Management periodically evaluates positions taken in tax returns with respect to situations in which applicable tax regulation is subject to interpretation. It establishes provisions, where appropriate, on the basis of amounts expected to be paid to the tax authorities. Management's judgements in this respect are based on assumptions and estimates, which carry a degree of uncertainty with respect to actual outcomes.

Non-taxable items primarily relate to individual Group companies, where tax losses are not capitalized.

(DKK '000)	2018	2017
<i>Tax on profit for the year:</i>		
Tax on profit/loss for the year	45.298	37.234
Tax on other comprehensive income	0	0
Total tax for the year	45.298	37.234

(DKK '000)	2018	2017
<i>Tax on profit/loss for the year can be broken down as follows:</i>		
Current tax for the year	46.402	36.095
Adjustment of deferred tax recognized in P&L	-852	1.139
Adjustments for current tax of prior periods	-252	0
Tax on profit/loss for the year	45.298	37.234

(DKK '000)	2018	2017
<i>Parent company's income tax rate</i>	22,0%	22,0%
<i>Tax effects of:</i>		
Higher/lower tax rate in subsidiaries	-1,6%	-0,5%
Non-taxable items	9,2%	2,4%
Adjustments in respect of prior years	-0,2%	0,0%
Revaluation of deferred tax assets and liabilities	-0,5%	0,5%
Effective tax rate	28,9%	24,4%

3.2 Deferred tax

Accounting policies

Deferred income tax is recognised on temporary differences arising between the tax bases of assets and liabilities and their carrying amounts in the Consolidated Financial Statements. However, deferred tax liabilities are not recognised if they arise from the initial recognition of goodwill; deferred income tax is not accounted for if it arises from the initial recognition of an asset or liability in a transaction other than a business combination that, at the time of the transaction, affects neither accounting nor taxable profit or loss. Deferred income tax is determined using tax rates (and laws) that have been enacted or substantively enacted by the balance sheet date and are expected to apply when the related deferred income tax asset is realised, or the deferred income tax liability is settled

Deferred income tax assets are recognised only to the extent that it is probable that future taxable profit will be available, against which the temporary differences can be utilised.

Deferred income tax assets and liabilities are offset when there is a legally enforceable right to offset current tax assets against current tax liabilities and when the deferred income tax assets and liabilities relate to income taxes levied by the same taxation authority on either the same taxable entity or different taxable entities where there is an intention to settle the balances on a net basis.

(DKK '000)	2018	2017
<i>Movement on deferred tax, net</i>		
Deferred tax liability at 1 January	186	-346
Deferred tax for the year	-852	1.139
Other adjustments	-912	-607
Deferred tax liability at 31 December	-1.578	186

The Group has non-recognized tax assets totalling DKK 19.357 thousand at year-end 2018, of which the majority relates to tax loss carry forwards. The unrecognized deferred tax assets have no significant time limitations.

4. Financial assets and liabilities

This note provides information about the Group's financial instruments, including:

- Overview of all financial instruments held by the Group
- Specific information about each type of financial instrument
- Accounting policies
- Information about determining the fair value of the instruments, including judgements and estimation uncertainty involved.

The Group holds the following financial instruments:

Financial assets (amortized cost)		
(DKK '000)	2018	2017
Trade receivables	729.084	443.172
Other receivables	92.052	44.570
Cash and Cash equivalents	157.988	175.907

Financial liabilities (amortized cost)		
(DKK '000)	2018	2017
Trade and other payables	806.530	487.293
Other financial liabilities	68.513	79.447

The Group's exposure to various risks associated with the financial instruments is discussed in note 6.3. The maximum exposure to credit risk at the end of the reporting period is the carrying amount of each class of financial assets mentioned above.

4.1 Receivables

Accounting policies

A receivable is the Group's unconditional right to consideration and is accounted for in accordance with IFRS 9. Receivables are initially recognised at fair value adjusted for any transaction costs. Subsequently, receivables are measured at amortised cost, which usually corresponds to the nominal value.

Trade Receivables are amounts due from customers for services performed in the ordinary course of business. They are generally due for settlement on a short-term basis and therefore are classified as current.

Trade receivables		
(DKK '000)	2018	2017
Trade receivables	750.313	450.690
Less provision for impairment	-21.229	-7.518
Trade receivables, net	729.084	443.172

Due to the short-term nature of the current receivables, their carrying amount is considered to be the same as their fair value.

Information about the impairment of trade receivables and the Group's exposure to credit risk, foreign currency and interest risk can be found in note 6.3.

4.2 Other receivables

Accounting policies

Other receivables generally arise from transaction outside the usual operating activities of the Group. The non-current other receivables consist of deposits, which are measured at cost less repayments and impairment.

4.3 Cash and cash equivalents

The cash and cash equivalents disclosed in the statement of cash flows include DKK 31.408 thousand which are held on restricted deposit accounts. Deposits are subject to regulatory restrictions and are therefore not available for general use by the other entities within the Group.

4.4 Trade and other payables

Accounting policies

Trade payables represents liabilities for services provided to the Group prior to the end of financial year which are unpaid. The amounts are unsecured and are usually paid on a short-term basis. Trade and other payables are presented as current liabilities unless payment is not due within 12 months after the reporting period. They are recognized initially at their fair value and subsequently measured at amortized cost using the effective interest method. The carrying amounts of trade and other payables are considered to be the same as their fair values, due to their short-term nature.

4.5 Other financial liabilities

Accounting policies

Other financial liabilities consist of individually immaterial positions related to leasing arrangements, short-term bank overdrafts, and other borrowing arrangements outside credit institutions.

Other financial liabilities are measured at amortised cost, which corresponds to the net realisable value.

Other financial liabilities are classified as current liabilities unless the Group has an unconditional right to defer settlement of the liability for at least 12 months after the reporting period.

(DKK '000)	Carrying amount	2018		
		0-1 year	1-5 years	> 5 years
Trade and other payables	806.530	806.530	0	0
Other financial liabilities	68.513	50.346	18.167	0
Total	875.043	856.876	18.167	0

(DKK '000)	Carrying amount	2017		
		0-1 year	1-5 years	> 5 years
Trade and other payables	487.293	487.293	0	0
Other financial liabilities	79.447	74.942	4.505	0
Total	566.740	562.235	4.505	0

5. Non-financial assets and liabilities

This note provides information about the Group's non-financial assets and liabilities: Intangible assets, property, plant and equipment and provisions

5.1 Intangible assets

Acquired other rights

Accounting policies

Acquired other similar rights are measured at cost less accumulated amortisation and less any accumulated impairment losses or at a lower value in use.

Goodwill

Accounting policies

Goodwill acquired in business combinations is recognised and measured as the difference between the total of the fair value of the consideration transferred and the fair value of the identifiable net assets of the date of acquisition. Goodwill is not amortized. The carrying amount of goodwill is tested for impairment annually. Impairment losses are recognized directly for the year and are not subsequently reversed.

(DKK '000)	2018			2017		
	Acquired rights	Goodwill	Total	Acquired rights	Goodwill	Total
Cost at 1 January	2.279	88.490	90.769	772	53.769	54.540
Additions from business combinations/ previous adjustments	290	240.287	240.577	0	35.564	35.654
Additions for the year	180	832	1.012	1.507	0	1.507
Disposals for the year	-1.240	0	-1.240	0	-880	-880
Currency translation adjustments	-200	372	172	0	37	37
Cost at 31 December	1.309	329.981	331.290	2.279	88.490	90.769
Impairment losses and amortisation at 1 January	0	0	0	0	0	0
Amortisation for the year	401	0	401	0	0	0
Amortisation of assets disposed of	0	0	0	0	0	0
Currency translation adjustments	-168	0	-168	0	0	0
Impairment losses and amortisations at 31 December	233	0	233	0	0	0
Carrying amount at 31 December	1.076	329.981	331.057	2.279	88.490	90.769

Impairment

Accounting policies

Goodwill is tested for impairment once a year, other intangible assets are tested when there is indication of impairment.

When performing the impairment test, an assessment is made as to the ability of individual cash generating units (CGUs) to generate sufficient positive net cash flow in the future to support the value of the unit in question.

Impairment testing is performed for each cash-generating unit to which consolidated goodwill is allocated, as defined by Management. The cash-generating units thereby follow the Group's divisional structure:

- Road & Logistics, and
- Air & Ocean

Goodwill is written down to its recoverable amount through the income statement, if this is lower than the carrying amount.

The recoverable amount is determined as the present value of the discounted future net cash flow from the cash-generating unit to which the goodwill relates. In calculating the present value, discount rates are applied reflecting the risk-free interest rate with the addition of risks relating to the individual cash-generating units, such as geographical and financial exposure.

The carrying amount of goodwill at the end of the reporting date equals DKK 330 million. For goodwill impairment testing, a number of estimates are made. Estimates are made in connection to the development in revenues, operating profits, future capital expenditures, discount rates and growth expectations in the terminal period. These estimates are based on assessments of the current cash-generating units Road & Logistics and Air & Ocean and are based on historical data and assumptions of future expected market developments, including expected long-term average market growth rates.

The Road & Logistics division primarily operates in the Northern, Eastern and Central European markets. Future net cash flows of the division are affected by market development and growth rates in these regions.

The Air & Ocean division operates internationally, and its future cash flows are therefore exposed to developments in global trade and economy.

Future cash flows in both divisions are also affected by the development of internal factors, such as network synergies and productivity improvements.

The expected future net cash flow is based on budgets and business plans approved by Management for the year 2019 and projections for subsequent years up to and including 2023. Projections are based on continued organic growth in line with historic performance of each segment. From 2023, Nordic Transport Group A/S expects the growth rate to remain in

line with the expected long-term average growth rate for the industry.

Goodwill impairment

(DKK '000)	2018	
	Road & Logistics	Air & Ocean
Carrying amount of goodwill	224.729	105.252
Budget period		
Annual growth	10,0%	11,0%
Operating margin	5,5%	3,5%
Terminal Period		
Growth	2,0%	2,0%
Pretax discount rate	10,0%	11,0%

(DKK '000)	2017	
	Road & Logistics	Air & Ocean
Carrying amount of goodwill	66.904	21.586
Budget period		
Annual growth	10,0%	11,0%
Operating margin	5,5%	3,5%
Terminal Period		
Growth	2,0%	2,0%
Pretax discount rate	10,0%	11,0%

5.2 Tangible assets and fixed assets investments

Property, plant and equipment

Accounting policies

Property, plant and equipment are measured at cost less accumulated depreciation and accumulated impairment. Property, plant and equipment are depreciated on a straight-line basis over the estimated useful lives of the assets, which are as follows:

- Land is not depreciated
- Warehouses and other productions buildings 20-30 years
- Office buildings 40-50 years
- Other plant and other operating equipment 3-7 years

The basis of depreciation is calculated with due consideration to the residual value and any prior impairment write down. The estimated useful life and residual value of each asset is determined at the date of acquisition and reassessed annually.

Impairment

Assets are tested for impairment, if indications of impairment are present. In case a need for impairment is identified, the asset's carrying amount is written down immediately to its recoverable amount if the asset's carrying amount is greater than loss is recognised in the income statement when the impairment is identified.

(DKK '000)	2018			2017		
	Land & buildings	Other fixtures and fittings, tools and equipment	Total	Land & buildings	Other fixtures and fittings, tools and equipment	Total
Cost at 1 January	4.549	18.261	22.810	0	9.284	9.284
Aquisitions through business combinations	17.049	16.201	33.250	4.549	6.654	11.203
Addtions for the year	0	17.753	17.753	0	2.823	2.823
Disposals at cost	0	-1.128	-1.128	0	0	0
Currency translation adjustments	236	851	1.087	0	-500	-500
Cost at 31 December	21.834	51.938	73.772	4.549	18.261	22.810
Impairment losses and depreciation at 1 January	0	8.206	8.206	0	5.717	5.717
Depreciation for the year	440	6.825	7.265	0	2.666	2.666
Disposals during the year	0	-1.064	-1.064	0	0	0
Currency translation adjustments	167	654	821	0	-177	-177
Impairment losses and depreciation at 31 December	607	14.621	15.228	0	8.206	8.206
Carrying amount at 31 December	21.227	37.317	58.544	4.549	10.055	14.604

5.3 Provisions

Accounting policies

Provisions are recognised when the Group has a present legal or constructive obligation as a result of past events, it is probable that an outflow of resources will be required to settle the obligation and the amount can be reliably estimated. Provisions are not recognised for future operating losses.

Where there are a number of similar obligations, the likelihood that an outflow will be required in settlement is determined by considering the class of obligations as a whole. A provision is recognised even if the likelihood of an outflow with respect to any one item included in the same class of obligations may be small.

Provisions are measured at the present value of Management's best estimate of the expenditure required to settle the present obligation at the end of the reporting period. The discount rate used to determine the present value is a pre-tax rate that reflects current market assessments of the time value of money and the risks specific to the liability. The increase in the provision due to the passage of time is recognised as interest expense.

The Group's provisions are divided into two categories. Provisions recognized through business combinations (see note 7.1 for further details) and other provisions. The latter primarily consists of provisions for restructuring, legal claims and similar obligations. The Group expects to utilize the main part of the

provisions within a period 3 years from the balance sheet date and the remaining part up to 5 years from the balance sheet date.

Movements during the year are primarily related to the segment Road & Logistics.

(DKK '000)	2018			(DKK '000)	2018		
	Current	Non-current	Total		Provisions through business combinations	Other provisions	Total
Other provisions	12.708	8.574	21.282	Carrying amount at start of the year	0	11.428	11.428
Provisions through business combinations	52.794	40.123	92.917	Acquired through business combination	118.350	0	118.350
Total	65.502	48.697	114.199	Additional provisions recognized	0	9.854	9.854
				Unused amounts reversed	0	0	0
				Amounts used during the year	-25.433	0	-25.433
				Carrying amount at end of year	92.917	21.282	114.199

6. Capital and financial risks

The section describes the shareholders' equity composition and capital management, including risks related to the financing structure of the Group.

6.1 Equity

Share capital

The share capital is broken down as follows:

(DKK '000)	A-shares	B-shares	Nominal value
1 January 2017	500	0	500
Capital increase	0	20	20
31 December 2017	500	20	520
Capital increase	6	0	6
31 December 2018	506	20	526

All shares are fully paid up and have a nominal value of DKK 1 each.

A-shares have a pre-emptive right to dividends and liquidation proceeds totalling DKK 799 per A-share.

Translation reserve

Exchange differences arising on translation of foreign controlled entities are recognised in other comprehensive income and accumulated in a separate reserve within equity. The

cumulative amount is reclassified to profit or loss when the net investment is disposed of.

Dividends

Dividends are recognized as a liability when approved by the shareholders at the Annual General Meeting. Dividends recommended to be paid for the year are stated as a separate line item under equity until approved at the Annual General Meeting.

6.2 Earnings per share

Earnings per share (EPS) is calculated according to IAS 33.

Earnings per share	2018	2017
(DK '000)		
Profit for the year, shareholders in NTG A/S ('000 shares)	42.407	58.886
Average number of shares	523	510
Earnings per share	81	115

6.3 Capital Management

The Group's objectives when managing capital are to safeguard the Group's ability to continue as a going concern in order to provide returns for shareholders and benefits for other stake-

holders and to maintain an optimal capital structure to reduce cost of capital.

Free cash flows are allocated in the priority below:

- Acquisition of new businesses with a strategic match to the Group's existing business
- Investment in promising start-ups within the Group's industry
- Repayment of external debt
- Distribution to the Group's shareholders through payment of dividends

Executive Management and the Board of Directors monitor the share- and capital structure to ensure that the Group's capital resources support the strategic goals. Through a close dialogue with its main lender, the Group has been able to decide on funding of strategic initiatives within a very short time frame.

6.4 Financial risks

The overall financial risk management framework is laid down in the Group's finance policy, investment policy and policies regarding credit risks. The Group's finance functions manage financial risk at centralized level. Thus, the Group's financial management is aimed solely at managing and reducing the financial risks directly associated with the Group's operations and financing.

During 2018, the Group has formalized further financial risk assessment procedures to prepare for the Group's stock-market introduction and to take into account the exposure to new currencies and markets following the year's acquisitions.

The Group is exposed to a few financial risks. The disclosures in this note solely concern the most critical financial risks, which are:

- Currency risk
- Liquidity risk
- Credit risk

In addition to the above mentioned risks the Group faces a minor interest rate risk.

Currency Risk

Foreign currency risk is the risk that the fair value of future cash flows of an exposure will fluctuate because of changes in foreign exchange rates. The Group's exposure to the risk of changes in foreign exchange rates relates primarily to the Group's operating activities due to the international activities of the Group. In all material aspects, the Group matches cash flows into a single currency per operating activity, thereby minimizing the currency exposure. The Group's revenues are mainly denominated in DKK, EUR, SEK, CHF and PLN. Expenses have a pattern in line with revenue. The expenses are mainly in DKK, EUR, SEK, CHF and PLN. The DKK rate is fixed to the EUR and is therefore not perceived to present a significant currency risk.

Sensitivity analysis of currency exposure based on the net exposure of the Group, the hypothetical impact of exchange rate fluctuations on the profit for the year end and equity, is as follows:

Sensitivity analysis			
(DKK '000)	Change in cross rate	Impact on profit/loss	Impact on OCI
CHF/DKK	-5%	420	-225
SEK/DKK	-5%	-1.606	0
PLN/DKK	-5%	-620	0

Liquidity risks

The Group is exposed to liquidity risk in relation to meeting future obligations associated with its financial liabilities, which mainly include trade payables, other payables and credit facility. The Group ensures adequate liquidity through the management of cash flow forecasts and close monitoring of cash inflows and outflows and through inter-Group treasury accounts. In addition to cash flow from operations, the Group's liquidity position is secured through a credit facility with the Group's primary bank. At year-end, the undrawn amount of this credit facility totalled DKK 100 million.

In all material aspects the financial liabilities are current in nature. Thus, the fair value of the financial assets and liabilities is considered equal to the booked value.

Credit risks

The Group's credit risks are partly linked to receivables and cash at bank and in hand. The maximum credit risk linked to financial assets corresponds to the values recognized in the balance sheet. The Group has no significant risk regarding one individual customer or partner and thus, there is no insurance of trade receivables.

During 2018, the Group expensed DKK 8 million on incurred and expected losses on trade receivables, corresponding to 0,2 % of the Group's net revenue.

Due to very low historic realized losses on trade receivables, the Group applies a simplified approach in calculating expected credit losses. Therefore, the Group does not track changes in credit risk, but instead recognizes a loss allowance based on lifetime expected credit losses at each reporting date. The Group has established a provision matrix that is based on its historical credit loss experience, adjusted for forward-looking factors specific to the debtors and the economic environment.

Expected losses on trade receivables, based on weighted loss percentages, are as follows:

Credit risks accounts receivable			
(DKK '000)	Gross carrying amount	Expected loss rate	Loss allowance
Not overdue	499.610	0,1%	500
1-30 days	177.016	0,1%	177
31-180 days	54.754	2,0%	1.095
181 - 360 days	6.375	50%	3.188
More than 360 days	12.558	100%	12.558
Loss allowance	750.313		17.518

At December 31, 2018 trade receivables were written down by DKK 21 million (2017: DKK 7.5 million). In addition to the calculated expected losses, DKK 4 million is provided for individual debtors, where settlement of accounts is assessed to be unlikely.

The closing loss allowances for trade receivables as at December 31, 2018 reconcile to the opening allowances as follows:

(DKK '000)	2018	2017
Carrying amount at the beginning of the year	7.518	8.783
Additions through business combinations	18.026	0
Received on impaired receivables during the year	-12.801	-4.904
Allowances for losses during the year	8.485	3.639
Carrying amount at the year-end	21.229	7.518

Impairment losses on trade receivables are presented as net impairment losses within operating profit. Subsequent recoveries of amounts previously written off are credited against the same line item.

Interest risk

Interest rate risk is the risk that the fair value of future cash flows of a financial instrument will fluctuate because of changes in market interest rates. The Group's exposure to interest risk arises mainly from the revolving credit facility held by Group. The material amount relates to short-term facilities and management expects to re-pay the credit facility in the short term, as the Group is generating positive cash flows. Therefore, exposure to interest rate risk is considered immaterial.

The Group regularly monitors its interest rate risk and considers it to be insignificant, therefore an interest rate sensitivity analysis is not deemed necessary.

7. Composition of the Group

This section provides information how the composition of the Group affects the financial position and performance for the year and the Group as a whole.

7.1 Acquisition and disposal of entities

Accounting policies

Enterprises acquired or formed during the year are recognized in the consolidated financial statements from the date of acquisition or formation. Enterprises disposed of are recognized in the consolidated financial statements up to the date of disposal. Discontinued operations and assets held for sale are presented separately.

The acquisition method of accounting is used to account for all business combinations, regardless of whether equity instruments or other assets are acquired. The consideration transferred for the acquisition of a subsidiary comprises:

- fair values of the assets transferred
- liabilities incurred to the former owners of the acquired business
- equity interests issued by the Group.

Identifiable assets acquired, and liabilities and contingent liabilities assumed in a business combination are, with limited exceptions, measured initially at their fair values at the acquisition date.

Estimates and assumptions are an integrated part of assessing fair values etc. in accordance with the acquisition method of accounting, as observable market prices are seldom available for the acquired assets and liabilities. Assessments are carried out using Management's judgement with regards to future cash flows and other input factors to the valuation models used. Significant estimates are mainly applied when measuring acquired trade receivables and provisions identified during fair value assessments of the acquired entities' operational commitments.

Acquisition-related costs are expensed as incurred as special items.

The excess of the consideration transferred over the fair value of the net identifiable assets acquired is recorded as goodwill. If those amounts are less than the fair value of the net identifiable assets of the business acquired, the difference is recognised directly in profit or loss as a bargain purchase.

Where settlement of any part of a cash consideration is deferred, the amounts payable in the future are discounted to their present value as at the date of exchange. The discount rate used is the entity's incremental borrowing rate, being the rate at which a similar borrowing could be obtained from an independent financier under comparable terms and conditions.

Contingent consideration is classified either as equity or a financial liability. Amounts classified as a financial liability are subsequently remeasured to fair value with changes in fair value recognised in profit or loss.

Acquisitions during the year

Gondrand International

On April 1, 2018 the Group acquired a 100% ownership interest in the Swiss-based transport group Gondrand International. Gondrand International has a strong position in the Central European market and activities within both of the Group's business segments.

Consideration transferred

The consideration paid for Gondrand International comprises a cash purchase of 100% of the shares in the company. The total consideration transferred amounted to DKK 51.568 thousand. Adjusted for the fair value of acquired cash and cash equivalents of DKK 82.044 thousand, the net cash flow amounted to DKK 30.476 thousand (inflow).

Earnings impact

During the 9 months since the acquisition date, the acquisition contributed with DKK 945.780 thousand to the Groups revenue and DKK 544 thousand to the result after tax. If the acquisition had taken place January 1, 2018 the Group's revenue would

have amounted to DKK 4.828.860 thousand and result after tax would have amounted to a DKK 103.353 thousand.

Transaction costs

Total transaction costs relating to the Gondrand acquisition amount to DKK 4.883 thousand. Transaction costs are accounted for in the income statement under "special items".

(DKK '000)	Fair value at date of acquisition
Intangible assets	290
Property, plant and equipment	29.706
Financial assets	7.956
Trade receivables	212.228
Other receivables	22.051
Cash and cash equivalents	82.044
Total assets	354.275
Provisions	118.350
Pensions and similar obligations	137.752
Other financial liabilities	3.338
Trade payables	230.089
Corporation tax	1.667
Other payables	21.019
Total liabilities	512.215
Non-controlling interests' share of acquired net assets	0
Acquired net assets	-157.940
Fair value of total consideration	51.568
Goodwill arising from the acquisition	209.506

The fair value of acquired trade receivables and other receivables amounted to DKK 226.413 thousand. Collectability of receivables has been assessed based on Group credit assessment policies. In total DKK 17.867 thousand has been provided for as doubtful trade receivables.

Provisions recognized during the business combination are primarily related to 3 warehouse locations, where a strategic mismatch was seen between the former Gondrand management's ambitions and the physical realities of the projects embarked on. It was apparent that these locations were obsolete at the time of NTG's acquisition of Gondrand International, and as such the non-avoidable costs directly attributable for the leasehold contracts etc. was provided for in the opening balance using base-case assumptions.

Goodwill is primarily connected to synergy effects that are expected to arise from the integration with the NTG Group concerning back-office and infrastructure setup and leveraging the NTG Group network. The goodwill is non-deductible for tax purposes.

NS Transcargo A/S and Combino East ApS

On March 1, 2018 the Group acquired a 51% ownership interest in the Danish-based transport company NS Transcargo A/S (name subsequently changed to NTG Nielsen & Sørensen A/S). The company primarily operates walking-floor and silo transports in Northern and Central Europe.

On September 1, 2018 the Group acquired a 56,1% ownership interest in the Danish-based transport company Combino East ApS (name subsequently changed to NTG Frigo East ApS). The company primarily transports frozen and cooled goods in Eastern Europe.

Information about the acquisitions of NS Transcargo A/S and Combino East ApS are disclosed in aggregate due to low materiality of the individual acquisition.

Consideration transferred

The total consideration transferred amounted to DKK 37.794 thousand. Adjusted for the fair value of cash and cash equivalents acquired of DKK 5.833 thousand, the net cash flow amounted to 31.961 thousand (outflow).

Earnings impact

During the 4 and 10 months since the acquisition date the subsidiaries contributed with DKK 156.390 thousand to the Groups revenue and DKK 5.396 thousand to the result after tax. If the acquisition would have taken place January 1, 2018 the Group's revenue would have amounted to DKK 4.577.634 thousand and result after tax would have amounted to a DKK 113.820 thousand.

Transaction costs

Total transaction costs relating to the acquisition amount to DKK 416 thousand. Transaction costs are accounted for in the income statement under "special items".

The acquisitions of NTG Nielsen & Sørensen A/S and NTG Frigo East ApS resulted in the recognition of the following fair values of net assets and goodwill:

(DKK '000)	Fair value at date of acquisition
Property, plant and equipment	3.544
Trade receivables	36.242
Other receivables	2.548
Cash and cash equivalents	5.833
Total assets	48.165
Financial liabilities	30.656
Corporation tax	686
Other payables	3.864
Total liabilities	35.207
Non-controlling interests' share of acquired net assets	5.946
Acquired net assets	7.013
Fair value of total consideration	37.794
Goodwill arising from the acquisition	30.781

The fair value of acquired trade receivables and other receivables amounted to DKK 38.789 thousand. Collectability of receivables has been assessed based on Group credit assessment policies. In total DKK 159 thousand has been provided for as doubtful trade receivables.

The acquisition of the two companies was an attractive strategic fit with solid performance and it is expected that NTG can drive the performance further on the existing strong foundation. The Goodwill is attributable to expertise and insight of the acquired business, and buyer synergies in relation to fertilizing future growth of the successful business models. The goodwill is non-deductible for tax purposes.

(DKK '000)

Cash flow from acquisition of business activities 2018

Net cash flow from Gondrand-acquisition	30.476
Net cash flow from other acquisitions	-31.961
Net cash flow from acquisitions	-1.485

Acquisitions in 2017

On April 1, 2017 the Group acquired 75,3 % ownership interest in the Finnish-based transport group Polar Logistics International Oy. The Polar Group was primarily represented in Finland and Eastern Europe.

Consideration transferred

The total consideration transferred amounted to DKK 33.902 thousand. Adjusted for the fair value of cash and cash equivalents acquired of DKK 2.966 thousand, the net cash flow amounted to 30.936 thousand (outflow).

The Polar Group-acquisition resulted in the recognition of the following fair values of net assets and goodwill:

(DKK '000)	Fair value at date of acquisition
Intangible assets	461
Property, plant and equipment	11.203
Receivables	111.824
Cash and cash equivalents	2.966
Total assets	126.454
Financial liabilities	116.202
Corporation tax	1.241
Total liabilities	117.443
Non-controlling interests' share of acquired net assets	10.301
Acquired net assets	-1.290
Fair value of total consideration	33.902
Goodwill arising from the acquisition	35.192

7.2 Non-controlling interest

It is an important part of the Group's strategy co-own companies with local management and key employees in order to provide the best possible incentive for growth and profitability in the Group's subsidiaries. As such, a large part of the Group's results is generated in subsidiaries, where local management and key employees hold a non-controlling ownership interest.

When a subsidiary reaches maturity (after approximately 5 years of operation), the intention is that minority shareholders agree on an equity swap with NTG A/S, thereby raising NTG A/S' ownership interest to 100 %.

After the balance sheet date, NTG A/S has agreed with holders of non-controlling interests in the below-mentioned Group subsidiaries to carry out equity swaps in immediate connection with approval of the Group's financial statements for 2018. These transactions would have had the following effects on the Group's financial statements, if carried out before the balance sheet date:

Effect on result distribution for 2018

Attributable to:	Presented in the consolidated financial statements	Effect of equity swap with non-controlling interests	After equity swap with non-controlling interests
Shareholders in NTG A/S	42.407	54.936	97.343
Non-controlling interests	69.116	-54.936	14.180

Effect on equity distribution in 2018

Attributable to:	Presented in the consolidated financial statements	Effect of equity swap with non-controlling interests	After equity swap with non-controlling interests
NTG A/S shareholders' share of equity	114.009	59.684	173.693
Non-controlling interests	93.898	-59.684	34.214

Company name	Principal place of business	Ownership % held by NTG A/S at 31 December 2018	Ownership % held by NTG A/S after equity swap
NTG Nordic A/S	Denmark	51,0 %	100,0 %
NTG Continent A/S	Denmark	51,0 %	100,0 %
NTG East A/S	Denmark	51,0 %	100,0 %
NTG Frigo A/S	Denmark	51,0 %	100,0 %
NTG Continent AB	Sweden	52,1 %	100,0 %
NTG Solution AB	Sweden	51,0 %	100,0 %
NTG East AB	Sweden	51,0 %	100,0 %

8. Other disclosures

This section of the notes includes other information that must be disclosed to comply with the accounting standards and other pronouncements.

8.1 Pension obligations

Accounting policies

The pension obligations of most group entities are covered by independent pension funds or insurance contracts (defined contribution plans) to which Group companies pay regular contributions. For a few Group companies, pension obligations are not covered or only partly covered by insurance (defined benefit plans).

For defined-benefit plans, the net present value is only calculated for those benefits earned to date by employees. The present value of future pension payments is estimated actuarially and shown net of the fair value of any plan assets in the balance sheet as pension obligations.

Differences between estimated pension assets and liabilities and their realized values are termed actuarial gains and losses. Actuarial gains and losses are recognized in the statement of other comprehensive income.

Changes in benefits earned to date are actuarially calculated and expensed immediately when the employees have already

earned the right to the changed benefits. Otherwise, they are recognized in the income statement over the period during which the employees earn the right to the benefits.

(DKK '000)	2018
Present value of pension liabilities at 31 December	243.126
Fair value of plan assets at 31 December	-107.969
Net value of pension plans at 31 December	135.157

Accounting estimates and judgments

Generally, pension plans within the Group are defined contribution plans, where contributions are recognised in the income statement on an accrual basis. These types of pension plans do not require material estimates.

For defined benefit plans, annual actuarial calculations are made of the net present value of future benefits to be paid under the plan. The net present value is calculated based on assumptions of the future developments of salary, interest, inflation, and mortality rates. Assumptions are assessed at the reporting date and changes in these assumptions may significantly affect the liabilities and pension cost under defined benefit plans.

Below is shown the most important assumptions made when determining the net present value of the defined benefit plans and a sensitivity analysis relating to these assumptions.

Most important assumptions for Actuarial calculations

	Germany	Switzerland	Weighted average
Discount rate	2,05%	0,80%	1,34%
Future salary increase	2,00%	0,50%	1,14%
Mortality prognosis	RT Heubeck 2018 G	BVG 2015	

Under defined benefit plans, the employer is obliged to pay a defined benefit (for example a fixed percentage of an employee's final salary) to the employee after retirement. The Group thereby carries a risk with respect of future developments in interest rates, inflation, mortality and disability.

Sensitivity analysis on reported pension liabilities

(DKK '000)	2018
Discount rate +0,5 %	-10.767
Discount rate -0,5 %	12.064
Future remuneration +0,5 %	891
Future remuneration -0,5 %	-1.117

The Group did not have defined benefit plan pensions prior to acquiring the Gondrand International transport group in 2018. As a consequence, no comparative figures for 2017 are presented.

Pensions liabilities

(DKK '000)	2018
At 1 January	0
Additions through business combinations	246.464
Foreign exchange adjustment	7.277
Contributions to the plan	5.765
Expensed in the income statement	3.826
Calculated interest	2.354
Actuarial loss/(gain) change in demographic assumptions	-4.311
Actuarial loss/(gain) change in financial assumptions	-3.571
Actuarial loss/(gain) experience adjustments	4.619
Benefits paid through pension assets	-19.296
Present value of pension liabilities at 31 December	243.126

Fair value of pension plan assets

(DKK '000)	2018
At 1 January	0
Additions through business combinations	108.712
Foreign exchange adjustment	5.612
Calculated interest	542
Return on plan assets in addition to calculated interest	-87
Contributions to the plan	8.605
Benefits paid through pension assets	-15.415
Fair value of plan assets at 31 December	107.969

Defined benefit plans in the Group are only related to Germany and Switzerland. The pension plan in Germany accounts for 77 % of the net liability at year-end and is closed for further accrual of benefits by the company's employees. Remaining plan participants in Germany receive benefits based on past service. In Switzerland, the pension plan is a result of the Swiss pension system's "second pillar", and offers old age pensions, survivors' and invalidity insurance. The plan is a fully insured BVG plan according to Swiss Federal Law on Occupational Benefits, meaning that the full actuarial risk is re-insured with a third-party life-insurance company.

Specification of plan assets

(DKK '000)	2018
Insurance contract	107.912
Cash	56
Total	107.969

	2018			2017		
(DKK '000)	Defined contribution plans	Defined benefit plans	Total	Defined contribution plans	Defined benefit plans	Total
Staff cost	25.443	3.826	29.269	16.488	0	16.488
Financial expenses	0	1.812	1.812	0	0	0
Total	25.443	5.638	31.081	16.488	0	16.488

The Group's plans are funded in accordance with applicable local legislation. At 31 December 2018 the Group has covered 44,4% of the pension liability.

The expected contributions to the Group plans for 2019 are DKK 11.428 thousand and the expected average duration of the obligations is 12,5 years.

Actuarial adjustments have no tax effect.

8.2 Leases

Accounting policies

A lease is classified at the inception date as a finance lease or an operating lease. A lease that transfers substantially all the risks and rewards incidental to ownership to the Group is classified as a finance lease.

Finance leases are capitalised at the commencement of the lease at the inception date fair value of the leased asset or, if lower, at the present value of the minimum lease payments. Lease payments are apportioned between finance charges and reduction of the lease liability so as to achieve a constant rate of interest on the remaining balance of the liability. Finance charges are recognised in finance costs in the statement of profit or loss.

A leased asset is depreciated over the useful life of the asset. However, if there is no reasonable certainty that the Group will obtain ownership by the end of the lease term, the asset is

depreciated over the shorter of the estimated useful life of the asset and the lease term.

An operating lease is a lease other than a finance lease. Operating lease payments are recognised as an operating expense in the income statement on a straight-line basis over the lease term.

Operating leases

The Group has entered into leases on office premises. Office premises have a lease term up to 15 years. The Group has also entered into leases on other plant and operating equipment. The lease terms are normally up to 5 years.

In 2018, operating lease costs of DKK 59.796 thousand relating to land and buildings were recognised in the income statement (2017: DKK 40.281 thousand).

In 2018, operating lease costs of DKK 36.228 thousand relating to other plant and operating equipment were recognised in the income statement (2017: DKK 38.701 thousand).

8.3 Fees to auditors appointed at the Annual general meeting

(DKK '000)	2018	2017
Statutory audit	2.247	1.188
Tax and VAT advisory services	380	0
Other Services	1.353	688
Total fees to auditors appointed at the Annual General Meeting	3.980	1.876

(DKK '000)	2018	2017
Statutory audit	419	0
Tax and VAT advisory services	19	0
Other Services	98	0
Other auditors, total fees	536	170

Operating leases

(DKK '000)	Land & buildings		Other plant and operating equipment	
	2018	2017	2018	2017
Within 1 year	79.066	33.868	82.597	32.420
Between 1 and 5 years	213.348	105.254	156.222	143.743
After 5 years	291.466	55.098	737	139
Total minimum future lease payments	583.879	194.220	239.556	176.302

8.4 Related party transactions

The Group's related parties include the Group's Board of Directors, the Executive Board and close family members of these persons. Related parties also include companies in which this circle of persons has significant interests. The Group has no related parties with control of the Group.

Management remuneration is disclosed in note 2.5.

The Group had the following transactions with key management personnel:

(DKK '000)	2018	2017
Sale of services to key management	2.452	1.463
Purchase of services from key management	47.540	26.112

The Group had the following balances with key management personnel at 31 December 2018:

(DKK '000)	2018	2017
Receivables towards key management	676	1.209
Liabilities towards key management	4.133	31.122

8.5 Commitments and contingent liabilities

A contingent liability is a potential liability that may occur depending on the outcome of an uncertain future event. A

contingent liability is recognized if the contingency is probable and the amount of the liability can be reasonably estimated.

The Group had commitment and contingent liabilities at 31 December 2018 of:

Claims

The Group is party to legal proceedings and inquiries from authorities when investigating various issues. The outcome of such is not expected to have a significant effect on profit for the year and the assessment of the Group's financial position.

Charges and security

The Group has provided bank guarantees to authorities and suppliers related to customs bond and rental agreements.

As of 31 December 2018, all liabilities related to bank guarantees amounted to DKK 65.729 thousand (2017: DKK 0 thousand) whereof DKK 11.289 thousand is already recognized in the balance sheet or described in note 8.2.

Pledges

At 31 December 2018, property, plant and equipment with a carrying value of DKK 4.485 thousand were pledged as security (2017: DKK 75.950 thousand).

8.6 Events after the reporting period

On 1 January 2019 NTG A/S acquired 100 % of the issued shares in D.A.P. (UK) Limited. The acquisition is expected to increase the Group's market presence in a new geographical

market and reduce cost through economies of scale in the acquired company. The fair value of the consideration totals DKK 35 million in cash payment, excluding a contingent consideration based on both realized performance and other factors. Valuation of the contingent consideration is not yet assessed by Group Management, and disclosure is therefore not possible.

The financial effects of this transaction have not been recognized at 31 December 2018. The operating results and assets and liabilities of the acquired company will be consolidated from 1 January 2019.

At the time the financial statements were authorized for issue, the Group had not yet completed the accounting for the acquisition of D.A.P. (UK) Limited. In particular, the fair values of the acquisition's assets and liabilities have yet been determined as the independent valuations have not been finalized. It is therefore not yet possible to provide detailed information about each class of acquired receivables and any contingent liabilities of the acquired entity. The acquisition's financial reporting has not yet been converted to the Group's reporting principles, and no disclosure is therefore made of the acquisitions past financial results.

Group structure

Name of entity	Place of Business / Country of incorporation	Ownership % by the ultimate Parent Company	Name of entity	Place of Business / Country of incorporation	Ownership % by the ultimate Parent Company	Name of entity	Place of Business / Country of incorporation	Ownership % by the ultimate Parent Company
Parent								
Nordic Transport Group A/S	Denmark	N/A	NTG Air & Ocean AB	Sweden	88%	NTG Continent Eood	Bulgaria	52%
			NTG Continent GmbH	Germany	51%	Go-Trans (Shanghai) Ltd.	China	100%
			NTG FTS GmbH	Germany	57%	Go-Trans (Shenzen) Ltd.	China	100%
Subsidiaries			NTG Logistics GmbH	Germany	51%	NTG Road Czech s.r.o.	Czech Republic	75%
NTG Nordic A/S	Denmark	51%	Polar Logistics GmbH	Germany	100%	Gondrand a.s.	Czech Republic	100%
NTG Continent A/S	Denmark	51%	ATEGE GmbH	Germany	100%	NTG Transport Oü	Estonia	51%
NTG Frigo A/S	Denmark	51%	NTG Road GmbH	Germany	100%	NTG Air & Ocean Estonia Oü	Estonia	75%
NTG East A/S	Denmark	51%	NTG Polar Road Oy	Finland	78%	Go Trans SAS	France	100%
NTG Terminals I A/S	Denmark	51%	Kiinteistö Eurospeed Oy	Finland	78%	Go-Trans (Hong Kong) Ltd.	Hong Kong	100%
NTG Terminals II A/S	Denmark	61%	Polar Logistics International Oy	Finland	100%	Gondrand Kft.	Hungary	100%
NTG Ocean International A/S	Denmark	60%	NTG Road Oy	Finland	100%	Transfin S.r.l.	Italy	100%
NTG Courier A/S	Denmark	73%	NTG Air & Ocean Oy	Finland	92%	Polar Eurasia TOO	Kazakhstan	100%
NTG Domestic A/S	Denmark	63%	KH Fur Oy	Finland	100%	NTG Latvia Sia	Latvia	51%
NTG Air & Ocean A/S	Denmark	78%	NTG Polar Holding Oy	Finland	59%	NTG Lithuania UAB	Lithuania	65%
NTG Projects A/S	Denmark	51%	Gondrand International AG	Switzerland	100%	NTG Logistics LT UAB	Lithuania	33%
Selskabet af 300918 ApS	Denmark	100%	NTG Air & Ocean Netherlands B.V.	Netherlands	59%	NTG Polar Road Sp.z.o.o.	Poland	51%
NTG Nielsen & Sørensen A/S	Denmark	51%	Gondrand Traffic B.V.	Netherlands	100%	NTG Global Poland sp. z.o.o.	Poland	60%
NTG Frigo East ApS	Denmark	51%	GT Chemical Logistics B.V.	Netherlands	100%	Polar Logistics Region ZAO	Russia	100%
NTG Domestic AB	Sweden	36%	NTG Road UK Ltd.	United Kingdom	100%	Polar Logistics Solution OOO	Russia	100%
NTG Logistics AB	Sweden	85%	NTG Ocean Inc.	United States	57%	Polar Logistics OOO	Russia	100%
NTG Road Sweden AB	Sweden	100%	NTG Ocean USA LLC	United States	57%	NTG Services s.r.o	Slovakia	85%
NTG East AB	Sweden	51%	NTG Road Norway AS	Norway	100%	NTG Uluslararası Lojistik Ltd.	Turkey	100%
NTG Continent AB	Sweden	52%	NTG Air & Ocean AS	Norway	100%	Polar Logistics Ukraine TOO	Ukraine	100%
NTG Solution AB	Sweden	51%	Polar Logistics Bel OOO	Belarus	100%			
NTG Växjö AB	Sweden	51%	NTG Eood	Bulgaria	100%	Associates		
NTG Turkey AB	Sweden	100%				ATS Air Transport Service AG	Switzerland	26%

Definition of financial highlights

Financial ratios and key figures are prepared in accordance with recommendations and guidelines issued by the Danish Society of Financial Analysts.

Key figures for financial position

Net working capital = Receivables and other current operating assets less trade payables and other current operating liabilities

Net interest-bearing debt = Interest-bearing debt less cash and cash-equivalents

Financial ratios

$$\text{Gross margin} = \frac{\text{Gross profit} \times 100}{\text{Net revenue}}$$

$$\text{Operating margin} = \frac{\text{Operating profit before special items} \times 100}{\text{Net revenue}}$$

$$\text{Conversion ratio} = \frac{\text{Operating profit before special items} \times 100}{\text{Gross profit}}$$

$$\text{Return on equity} = \frac{\text{Profit for the year} \times 100}{\text{Average equity}}$$

$$\text{Solvency ratio} = \frac{\text{Equity at year end} \times 100}{\text{Total assets at year end}}$$

$$\text{Earnings per share} = \frac{\text{Profit attributable to shareholders in Nordic Transport Group A/S}}{\text{Average number of shares}}$$

Statement of the Board of Directors and the Executive Board

The Board of Directors and the Executive Board have considered and adopted the Annual Report of Nordic Transport Group A/S for the financial year 1 January – 31 December 2018.

The Consolidated Financial Statements have been prepared in accordance with International Financial Reporting Standards as adopted by the EU and further requirements in the Danish Financial Statements Act, and the Parent Company Financial Statements have been prepared in accordance with the Danish Financial Statements Act. Management's Review has been prepared in accordance with the Danish Financial Statements Act.

In our opinion, the Consolidated Financial Statements and the Parent Company Financial Statements give a true and fair view of the financial position at 31 December 2018 of the Group and the Parent Company and of the results of the Group and Parent Company operations and consolidated cash flows for the financial year 1 January - 31 December 2018.

In our opinion, Management's Review includes a true and fair account of the development in the operations and financial circumstances of the Group and the Parent Company, of the

results for the year and of the financial position of the Group and the Parent Company.

We recommend that the Annual Report be adopted at the Annual General Meeting.

Hvidovre, 4 April 2019

Executive Board

Jesper E. Petersen
CEO, Road & Logistics

Mikkel Fruergaard
CEO, Air & Ocean

Christian D. Jakobsen
Group CFO

Board of Directors

Morten Mathiesen
Chairman of the board

Jørgen Hansen
Vice chairman of the board

Michael Larsen
Board member

Finn Skovbo Pedersen
Board member

Peter Grubert
Board member

Stefan Pettersson
Board member

Ulrik Ross
Board member

Independent auditors' report

To the Shareholders of
Nordic Transport Group A/S

Opinion

In our opinion, the Consolidated Financial Statements give a true and fair view of the Group's financial position at 31 December 2018 and of the results of the Group's operations and cash flows for the financial year 1 January to 31 December 2018 in accordance with International Financial Reporting Standards as adopted by the EU and further requirements in the Danish Financial Statements Act.

Moreover, in our opinion, the Parent Company Financial Statements give a true and fair view of the Parent Company's financial position at 31 December 2018 and of the results of the Parent Company's operations for the financial year 1 January to 31 December 2018 in accordance with the Danish Financial Statements Act.

We have audited the Consolidated Financial Statements and the Parent Company Financial Statements of Nordic Transport Group A/S for the financial year 1 January - 31 December 2018, which comprise income statement, balance sheet, statement of changes in equity and notes, including accounting policies, for both the Group and the Parent Company, as well

as statement of comprehensive income and cash flow statement for the Group ("financial statements").

Basis for Opinion

We conducted our audit in accordance with International Standards on Auditing (ISAs) and the additional requirements applicable in Denmark. Our responsibilities under those standards and requirements are further described in the Auditor's Responsibilities for the Audit of the Financial Statements section of our report. We are independent of the Group in accordance with the International Ethics Standards Board for Accountants' Code of Ethics for Professional Accountants (IESBA Code) and the additional requirements applicable in Denmark, and we have fulfilled our other ethical responsibilities in accordance with these requirements. We believe that the audit evidence we have obtained is sufficient and appropriate to provide a basis for our opinion.

Statement on Management's Review

Management is responsible for Management's Review.

Our opinion on the financial statements does not cover Management's Review, and we do not express any form of assurance conclusion thereon.

In connection with our audit of the financial statements, our responsibility is to read Management's Review and, in doing

so, consider whether Management's Review is materially inconsistent with the financial statements or our knowledge obtained during the audit, or otherwise appears to be materially misstated.

Moreover, it is our responsibility to consider whether Management's Review provides the information required under the Danish Financial Statements Act.

Based on the work we have performed, in our view, Management's Review is in accordance with the Consolidated Financial Statements and the Parent Company Financial Statements and has been prepared in accordance with the requirements of the Danish Financial Statement Act. We did not identify any material misstatement in Management's Review.

Management's Responsibilities for the Financial Statements

Management is responsible for the preparation of Consolidated Financial Statements that give a true and fair view in accordance with International Financial Reporting Standards as adopted by the EU and further requirements in the Danish Financial Statements Act and for the preparation of Parent Company Financial Statements that give a true and fair view in accordance with the Danish Financial Statements Act, and for such internal control as Management determines is necessary

to enable the preparation of financial statements that are free from material misstatement, whether due to fraud or error.

In preparing the financial statements, Management is responsible for assessing the Group's and the Parent Company's ability to continue as a going concern, disclosing, as applicable, matters related to going concern and using the going concern basis of accounting in preparing the financial statements unless Management either intends to liquidate the Group or the Parent Company or to cease operations, or has no realistic alternative but to do so.

Auditor's Responsibilities for the Audit of the Financial Statements

Our objectives are to obtain reasonable assurance about whether the financial statements as a whole are free from material misstatement, whether due to fraud or error, and to issue an auditor's report that includes our opinion. Reasonable assurance is a high level of assurance, but is not a guarantee that an audit conducted in accordance with ISAs and the additional requirements applicable in Denmark will always detect a material misstatement when it exists. Misstatements can arise from fraud or error and are considered material if, individually or in the aggregate, they could reasonably be expected to influence the economic decisions of users taken on the basis of these financial statements.

As part of an audit conducted in accordance with ISAs and the additional requirements applicable in Denmark, we exercise professional judgment and maintain professional skepticism throughout the audit. We also:

- Identify and assess the risks of material misstatement of the financial statements, whether due to fraud or error, design and perform audit procedures responsive to those risks, and obtain audit evidence that is sufficient and appropriate to provide a basis for our opinion. The risk of not detecting a material misstatement resulting from fraud is higher than for one resulting from error as fraud may involve collusion, forgery, intentional omissions, misrepresentations, or the override of internal control.
- Obtain an understanding of internal control relevant to the audit in order to design audit procedures that are appropriate in the circumstances, but not for the purpose of expressing an opinion on the effectiveness of the Group's and the Parent Company's internal control.
- Evaluate the appropriateness of accounting policies used and the reasonableness of accounting estimates and related disclosures made by Management.
- Conclude on the appropriateness of Management's use of the going concern basis of accounting in preparing the financial statements and, based on the audit evidence obtained, whether a material uncertainty exists related to events or conditions that may cast significant doubt on the Group's and the Parent Company's ability to continue as a going concern. If we conclude that a material uncertainty exists, we are required to draw attention in our auditor's report to the related disclosures in the financial statements or, if such disclosures are inadequate, to modify our opinion. Our conclusions are based on the audit evidence obtained up to the date of our auditor's report. However, future events or conditions may cause

the Group and the Parent Company to cease to continue as a going concern.

- Evaluate the overall presentation, structure and contents of the financial statements, including the disclosures, and whether the financial statements represent the underlying transactions and events in a manner that gives a true and fair view.
- Obtain sufficient appropriate audit evidence regarding the financial information of the entities or business activities within the Group to express an opinion on the Consolidated Financial Statements. We are responsible for the direction, supervision and performance of the group audit. We remain solely responsible for our audit opinion.

We communicate with those charged with governance regarding, among other matters, the planned scope and timing of the audit and significant audit findings, including any significant deficiencies in internal control that we identify during our audit.

Copenhagen, 4 April 2019

Price Waterhouse Coopers

Statsautoriseret Revisionspartnerselskab

CVR No. 33 77 12 31

Flemming Eghoff
State Authorized
Public Accountant
mne30221

Morten Jørgensen
State Authorized
Public Accountant
mne32806

Income Statement

DKK '000	Note	2018	2017
Net revenue		40.658	39.380
Gross profit		40.658	39.380
Other external expenses		-31.099	-29.258
Staff costs	1	-17.434	-6.960
Operating profit		-7.875	3.162
Income from investments in Group companies	4	46.402	60.343
Financial income	2	2.040	1.876
Financial costs	2	-10.022	-5.995
Profit before tax		30.545	59.386
Tax on profit for the year	3	299	-82
Profit for the year		30.844	59.304

Balance Sheet

Assets

DKK '000	Note	2018	2017
Investments in Group companies	4	256.166	169.108
Other investments		0	1.044
Receivables from Group companies		20.499	0
Total non-current assets		276.665	170.152
Trade receivables		658	265
Receivables from Group companies		40.671	99.334
Other receivables		13.304	5.807
Cash and cash equivalents		29	31
Total current assets		54.662	105.437
Total assets		331.327	275.589

Equity and Liabilities

DKK '000	Note	2018	2017
Share capital	5	526	520
Reserve for net revaluation under the equity method		8.724	33.254
Retained earnings		113.576	72.567
Total equity	6	122.826	106.341
Other provisions	7	12.345	838
Total provisions		12.345	838
Credit institutions	8	11.392	3.000
Payables in connection to purchase		0	59.500
Trade payables		9.695	3.630
Payables to Group companies		158.730	81.757
Other payables		13.876	7.282
Corporation tax		2.463	13.241
Total current liabilities		196.156	168.410
Total liabilities		208.501	169.248
Total equity and liabilities		331.327	275.589

Other notes:

Note 9 - Contingent liabilities and other financial obligations

Note 10 - Related party transactions

Statement of Changes in Equity

2018

DKK '000	Share capital	Share premium	Reserve for net revaluation under the equity method	Retained earnings	Total equity
Equity at 1 January	520	0	33.255	72.566	106.341
Profit for the year	0	0	-3.203	34.047	30.844
Net exchange differences on subsidiaries	0	0	-5.682	0	-5.682
Share conversion with minority shareholders	6	6.934	-4.297	0	2.643
Transactions with minority shareholders	0	0	-14.524	0	-14.524
Other adjustments	0	-6.934	3.175	6.963	3.204
Equity at 31 December	526	0	8.724	113.576	122.826

2017

DKK '000	Share capital	Share premium	Reserve for net revaluation under the equity method	Retained earnings	Total equity
Equity at 1 January	500	0	24.752	20.468	45.720
Profit for the year	0	0	7.514	51.790	59.304
Net exchange differences on subsidiaries	0	0	-341	0	-341
Capital increase	20	308	0	0	328
Other adjustments	0	-308	1.330	308	1.330
Equity at 31 December	520	0	33.255	72.566	106.341

Accounting policies

Nordic Transport Group A/S' parent company financial statements are disclosed as separate financial statements as required by the Danish Financial Statements Act.

The Annual Report of Nordic Transport Group A/S for 2018 has been prepared in accordance with the provisions of the Danish Financial Statements Act applying to medium-sized enterprises of reporting class C .

The Consolidated and Parent Company Financial Statements for 2018 are presented in DKK thousand.

Accounting policies are unchanged from last year.

Translation policies

Transactions in foreign currencies are translated at the exchange rates at the dates of transaction. Exchange differences arising due to differences between the transaction date rates and the rates at the dates of payment are recognised in financial income and expenses in the income statement.

Receivables, payables and other monetary items in foreign currencies that have not been settled at the balance sheet date are translated at the exchange rates at the balance sheet date. Any differences between the exchange rates at the balance

sheet date and the rates at the time when the receivable or the debt arose are recognised in financial income and expenses in the income statement.

Cash flow statement

No separate cash flow statement has been prepared for the parent company in accordance with the exemption clause of section 86(4) of the Danish Financial Statements Act.

Income statement

Revenue

Revenue from the sale of services etc. is recognised in the income statement provided that delivery and transfer of risk have been made to the purchaser by year end and provided that the revenue can be measured reliably and it is probable that the economic benefits relating to the sale will flow to the Company.

Revenue is measured at the consideration received and is recognised exclusive of VAT and net of discounts relating to sales.

Other external expenses

Other external expenses comprise expenses for distribution, sales, marketing, administration, premises, bad debts as well as leases, etc.

Staff costs

Staff expenses comprise wages and salaries as well as payroll expenses.

Income from investments in subsidiaries

The item "Income from investments in subsidiaries" in the income statement includes the proportionate share of profit for the year, including amortisations of goodwill arising at initial recognition and other value adjustments on subsidiaries.

Financial income and costs

Financial income and costs comprise interests, realized and unrealized gain from exchange rates as well as other financial income and expenses.

Tax on profit/loss for the year

Tax for the year consists of current tax for the year and changes in deferred tax for the year. The tax attributable to the profit for the year is recognised in the income statement, whereas the tax attributable to equity transactions is recognised directly in equity.

The Company is jointly taxed with its Danish subsidiaries. The tax effect of the joint taxation is allocated to enterprises in proportion to their taxable incomes.

Balance sheet

Investments in subsidiaries and Group goodwill

Investments in subsidiaries are recognised and measured under the equity method.

The item "Investments in subsidiaries" in the balance sheet include the proportionate ownership share of the net asset value of the enterprises calculated on the basis of the fair values of identifiable net assets at the time of acquisition with deduction or addition of unrealised intercompany profits or losses and with addition of the remaining value of any increases in value and goodwill calculated at the time of acquisition of the enterprises.

The total net revaluation of investments in subsidiaries is transferred upon distribution of profit to "Reserve for net revaluation under the equity method" under equity. The reserve is reduced by dividend distributed to the Parent Company and adjusted for other equity movements in the subsidiaries.

Subsidiaries with a negative net asset value are recognised at DKK 0. Any legal or constructive obligation of the Parent Company to cover the negative balance of the enterprise is recognised in provisions

Group goodwill arising at initial recognition of subsidiaries is amortised on a straight-line basis over the estimated useful life of 20 years, determined on the basis of Management's experience with the individual business areas. The useful life of goodwill relates mainly to the investment in subsidiaries, and

is described further in the consolidated financial statements, note 5.1. It is Management's assessment that the acquired companies are a strategic investment for the Group and will contribute positively to the Group's earnings over a longer period due to good market positions and strong earnings potentials.

Receivables

Receivables are measured in the balance sheet at amortised cost, which substantially corresponds to nominal value. Provisions for estimated bad debts are made.

Equity - dividend

Dividend distribution proposed by Management for the year is disclosed as a separate equity item.

Current tax receivables and liabilities

Current tax liabilities and receivables are recognised in the balance sheet as the expected taxable income for the year adjusted for tax on taxable incomes for prior years and tax paid on account. Extra payments and repayment under the onaccount taxation scheme are recognised in the income statement in financial income and expenses.

Financial debts

Loans, such as loans from credit institutions, are recognised initially at the proceeds received net of transaction expenses incurred. Subsequently, the loans are measured at amortised cost; the difference between the proceeds and the nominal

value is recognised as an interest expense in the income statement over the loan period.

Other debts are measured at amortised cost, substantially corresponding to nominal value.

Provisions

Provisions are recognised when the Group has a present legal or constructive obligation as a result of past events, it is probable that an outflow of resources will be required to settle the obligation and the amount can be reliably estimated. Provisions are not recognised for future operating losses.

Where there are a number of similar obligations, the likelihood that an outflow will be required in settlement is determined by considering the class of obligations as a whole. A provision is recognised even if the likelihood of an outflow with respect to any one item included in the same class of obligations may be small.

Provisions are measured at the present value of Management's best estimate of the expenditure required to settle the present obligation at the end of the reporting period. The discount rate used to determine the present value is a pre-tax rate that reflects current market assessments of the time value of money and the risks specific to the liability. The increase in the provision due to the passage of time is recognised as interest expense.

Notes

Note 1 - Staff costs

(DKK '000)	2018	2017
Wages and salaries	14.470	5.668
Pensions	2.452	1.164
Other social security costs and other staff costs	512	128
Total	17.434	6.960
Average full time employees	27	19

For details on remuneration on the Board of Directors and company's Executive management, please refer to note 2.5 in the consolidated financial statements.

Note 2 - Financial income and costs

(DKK '000)	2018	2017
Interest received from Group companies	1.565	1.060
Other financial income	475	816
Total Total financial income	2.040	1.876
Interest paid to Group companies	2.702	4.101
Other financial costs	7.320	1.894
Total financial costs	10.022	5.995
Net financials	-7.982	-4.119

Note 3 - Tax

(DKK '000)	2018	2017
<i>Tax for the year can be broken down as follows:</i>		
Current tax for the year	-462	82
Adjustment of tax from prior periods	163	0
Total	-299	82

Note 4 - Investments in subsidiaries

(DKK '000)	2018	2017
Cost at 1 January	115.345	73.431
Additions for the year	125.823	42.977
Disposals for the year	-22.400	-1.063
Movement from cost to value adjustments	-2.593	0
Cost at 31 December	216.175	115.345
Value adjustments at 1 January	33.254	24.752
Net profit/loss for the year	65.054	69.082
Dividend to parent company	-71.018	-44.133
Other equity movements, net	3.175	1.329
Amortisation of goodwill	-12.313	-3.126
Currency translation adjustments	-5.682	-341
Change in intercompany profit	-6.995	-5.613
Other adjustments	656	-8.696
Movement from cost to value adjustments	2.593	0
Value adjustments at 31 December	8.724	33.254
Equity investments with negative net asset value offset against receivables	23.922	19.671
Equity investments with negative net asset value transferred to provisions	7.345	838
Carrying value at 31 December	256.166	169.108
Positive differences from initial measurement of subsidiaries at net asset value	252.370	24.891

Reference is made to the consolidated financial statements, section "Group Structure", where all legal entities in the Group are listed.

Note 5 - Equity

Share capital:

The composition of share capital is stated in note 6.1 of the consolidated financial statements.

Note 6 - Proposed distribution of profit

(DKK '000)	2018	2017
Reserve for net revaluation cf. equity method	-3.203	7.514
Retained earnings	34.047	51.790
Total	30.844	59.304

Note 7 - Provisions

(DKK '000)	Investments with negative values	Other provisions	Total provisions
Carrying amount at 1 January	838	0	838
Additional provisions recognized	6.507	5.000	11.507
Total	7.345	5.000	12.345

Note 8 - Financial liabilities

(DKK '000)	2018	2017
Due within 1 year from the balance sheet date	11.392	3.000
Total	11.392	3.000

Note 9 - Contingent liabilities and other financial obligations

(DKK '000)	2018	2017
<i>Future lease payments on operating leases:</i>		
Within 1 year	17.193	16.126
Between 1 and 5 years	68.027	62.475
After 5 years	177.899	30.064
Total	263.119	108.665

Other contingent liabilities:

The Danish group companies are jointly and severally liable for tax on the jointly taxed incomes etc of the Group. Moreover, the Danish group companies are jointly and severally liable for Danish withholding taxes by way of dividend tax, tax on royalty payments and tax on unearned income. Any subsequent adjustments of corporation taxes and withholding taxes may increase the Company's liability.

Note 10 - Related party transactions

All related party transactions have been carried out in accordance with the arms-length principle.

For transactions with related parties, please refer to note 8.4 in the consolidated financial statements.

